

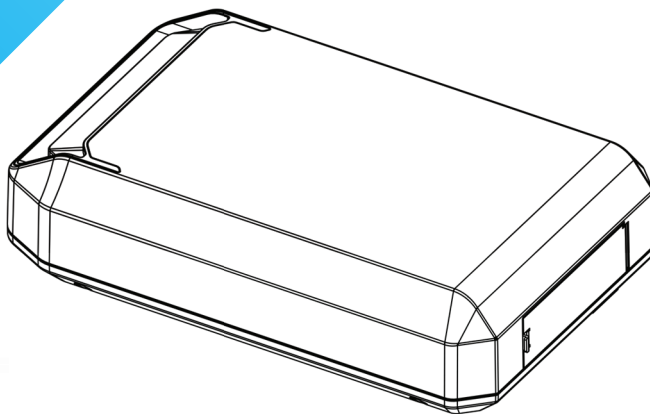

CONTROL

Garasjeportåpner

MONTERINGS- OG
BRUKSANVISNING



ADVARSEL: VENNLIGST LES VEILEDNINGEN NØYE FØR INSTALLASJON OG BRUK.

DET ER KРИTISK AT DE PERSONER SOM INSTALLERER OG BENYTTET SEG AV PRODUKTET FØLGER INSTALLASJONSVEILEDNINGEN OG SIKKERHETSADVARSLERNE. MANGEL PÅ Å FØLGE DETTE KAN RESULTERE I ALVORLIG PERSONSKADE, DØDSFALL, SKADE PÅ EIENDOM ELLER SKADE PÅ PRODUKTET.

1. Tekniske Data

Inngangspenning	220V AC 50 60Hz
Motor	24V DC
Arbeidstemperatur	-20 °C - +50 °C
Trekraft	800N 1000N
Frekvens	433.92MHz
Kodeformat	Rullerende kode (7.38 x 10 ¹⁹ kombinasjoner)
Sendere	2 stk fjernkontroll pr. motorpakke
Senderens batteri	27A 12V
Lampe	LED
Total lengde monterert	3710 mm
Ledning	1400 mm

2. Pakkens innhold

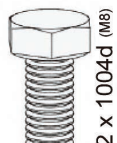
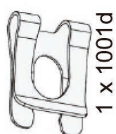

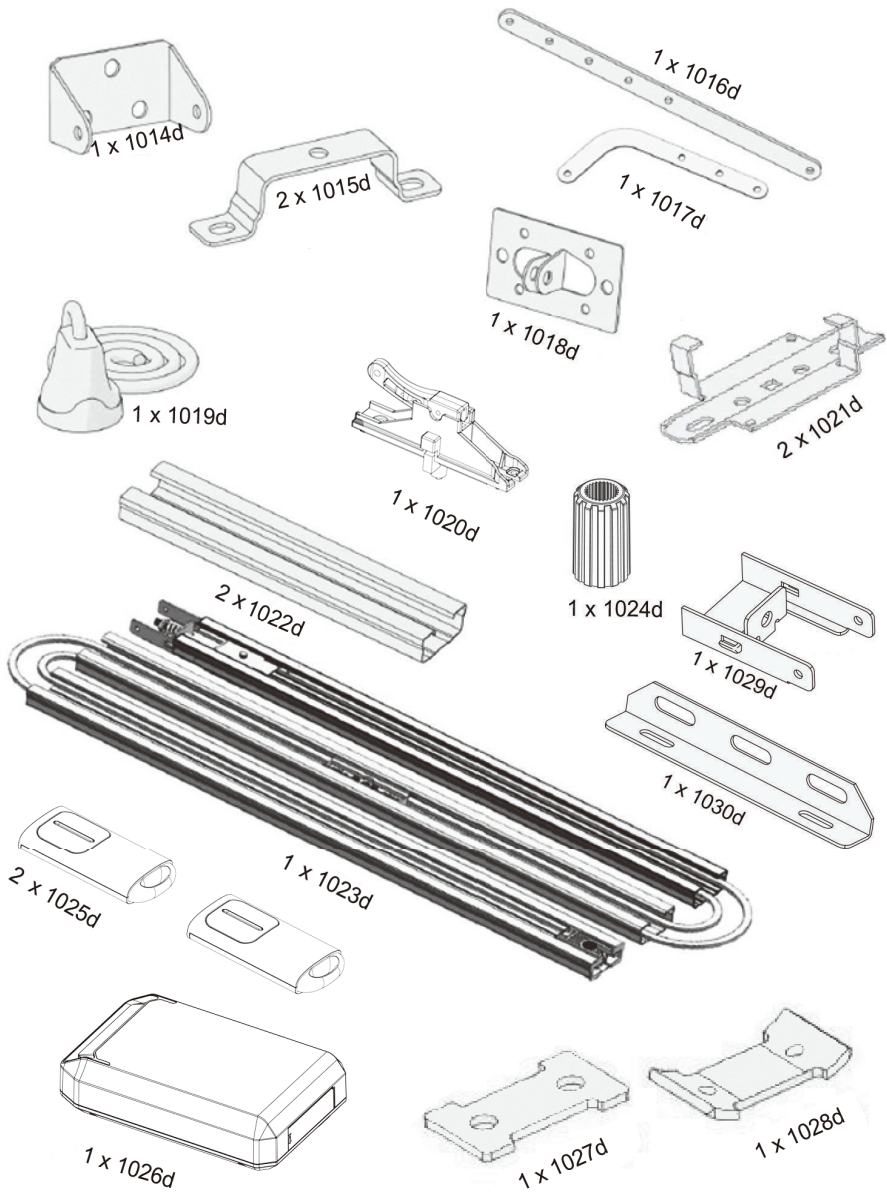

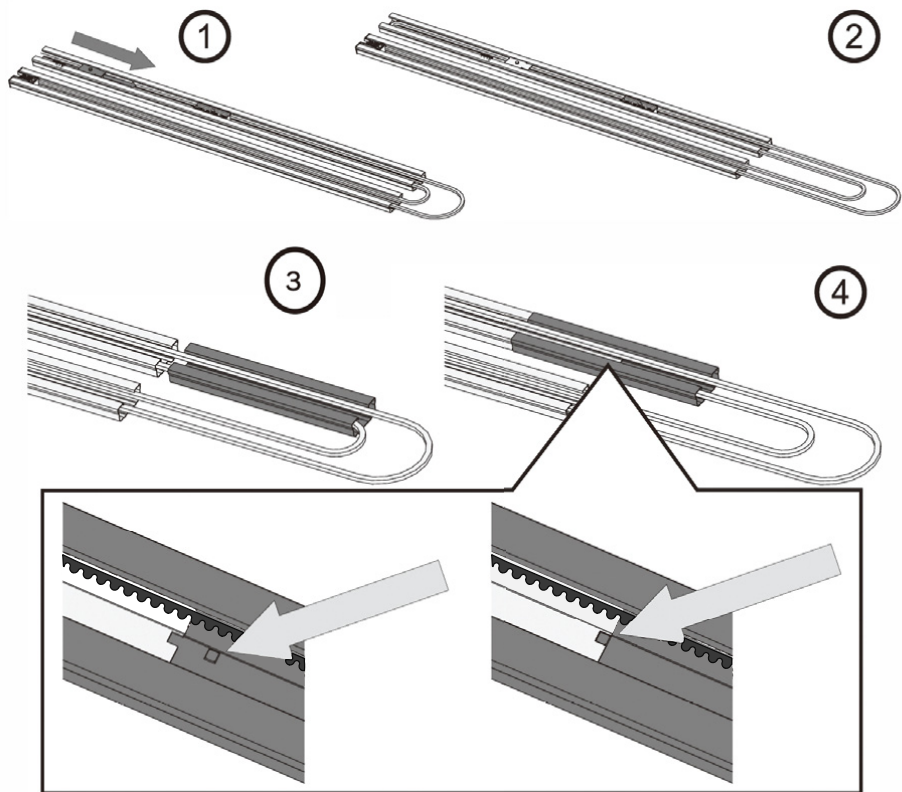

Sett sammen motortrekket ved hjelp av skjøteleddene.

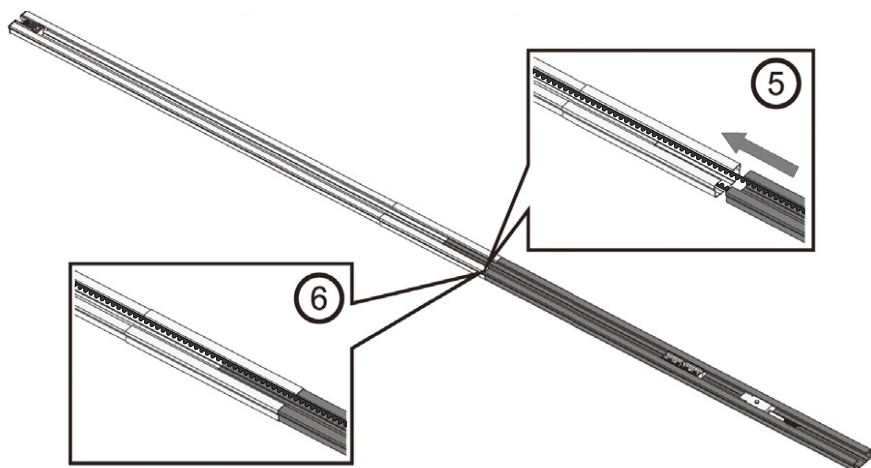

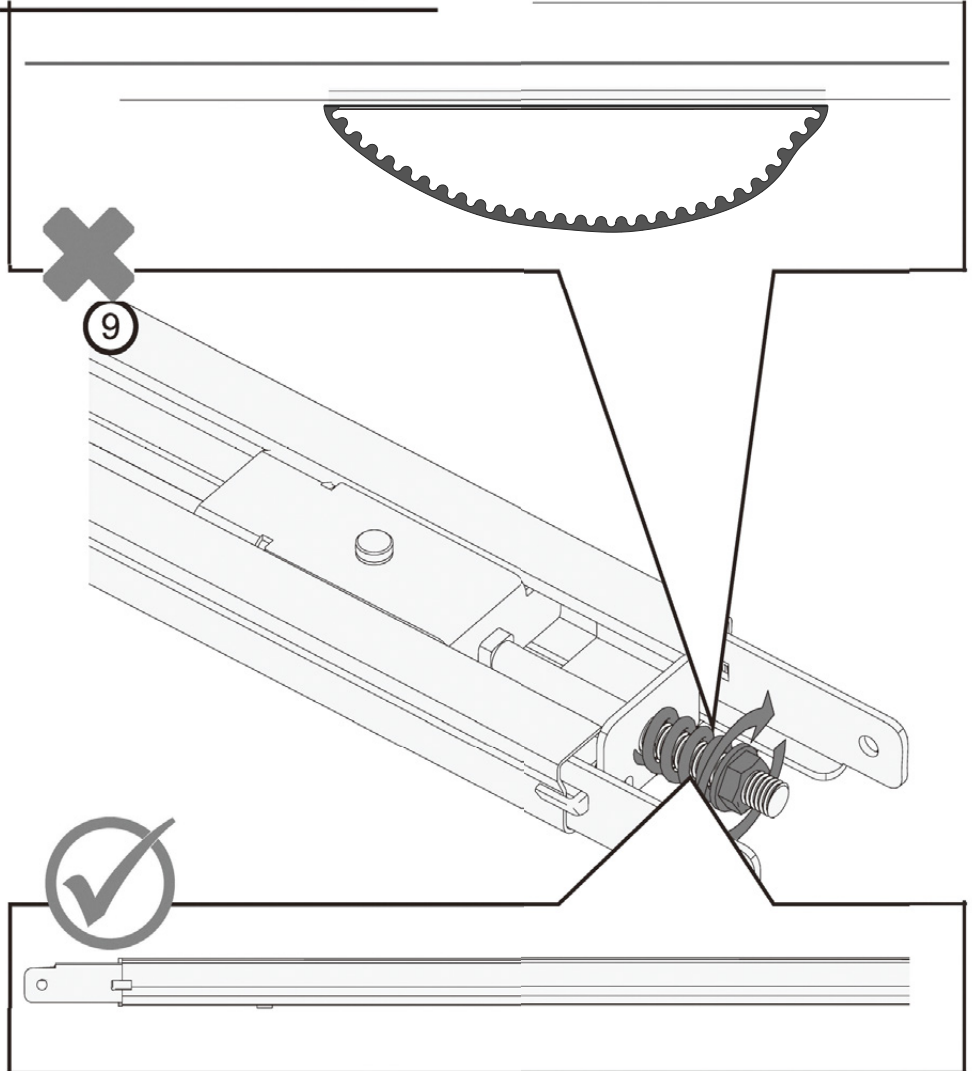
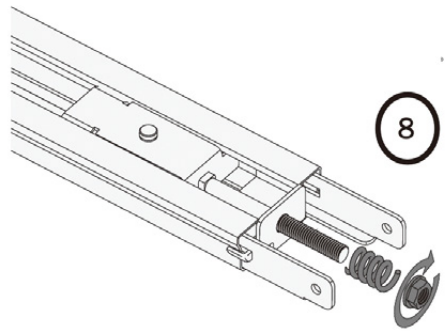
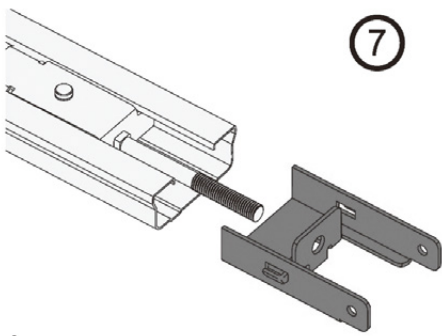

10

1. Sett sammen sylinder 1008d med L arm 1017d i sporet på trekkvognen.

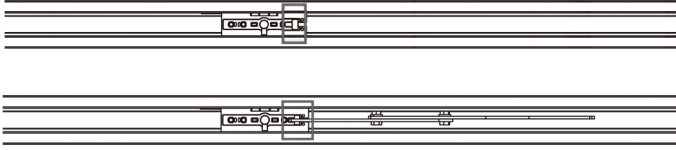

2. Monter L armen til trekkvognen med bolt 1009d og skruene 1007d.

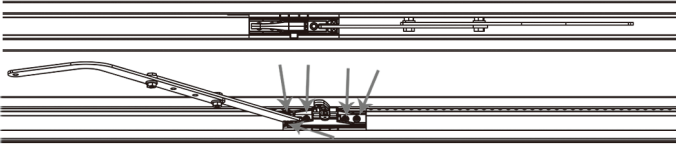

Bilde 13. OBS: Ikke stram boltene for hardt (håndkraft)

11

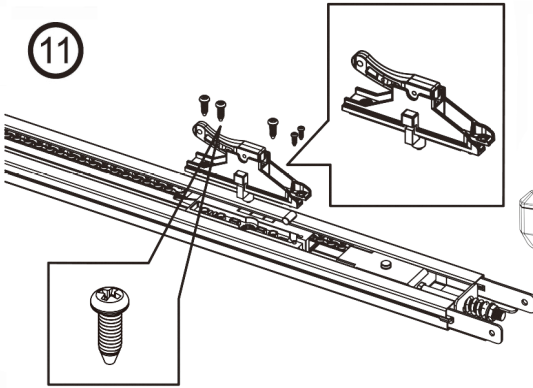

12

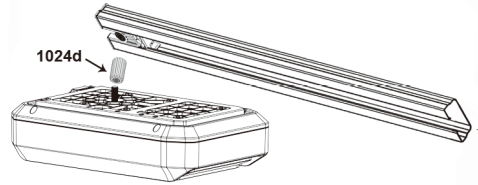

13

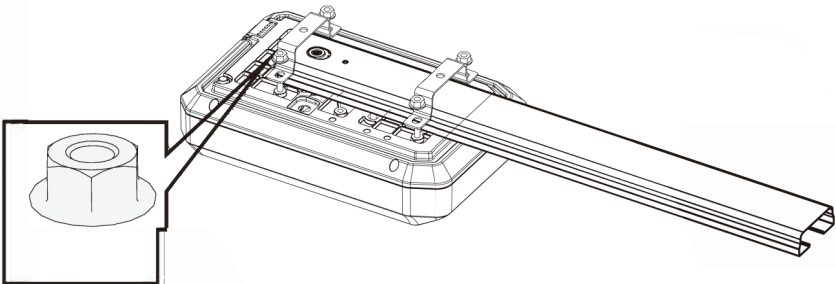

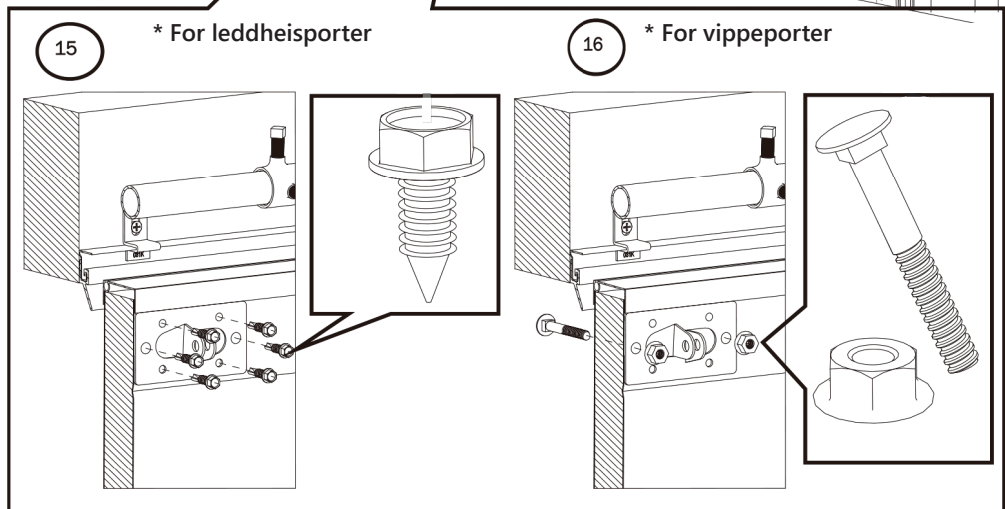
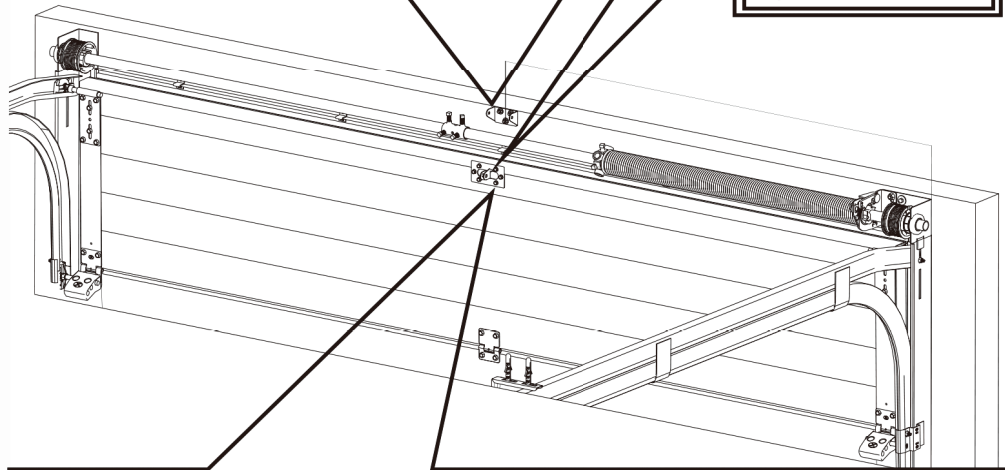
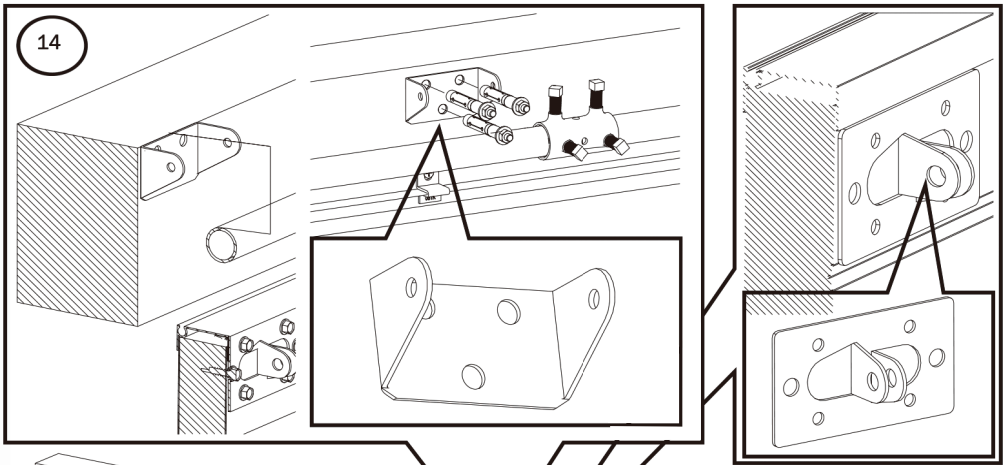

17

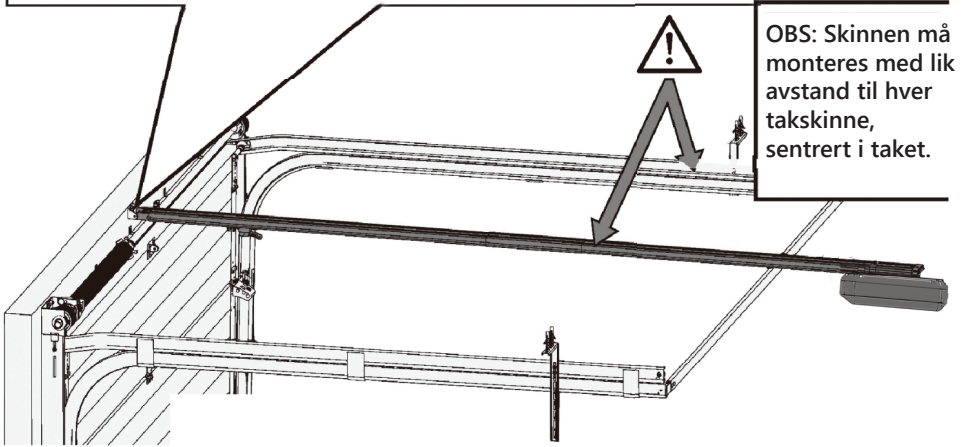
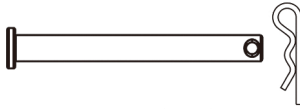
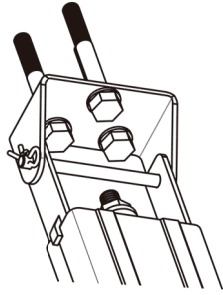
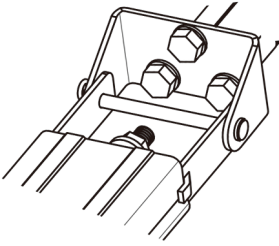

OBS: Skinnen må monteres med lik avstand til hver takskinne, sentrert i taket.

18

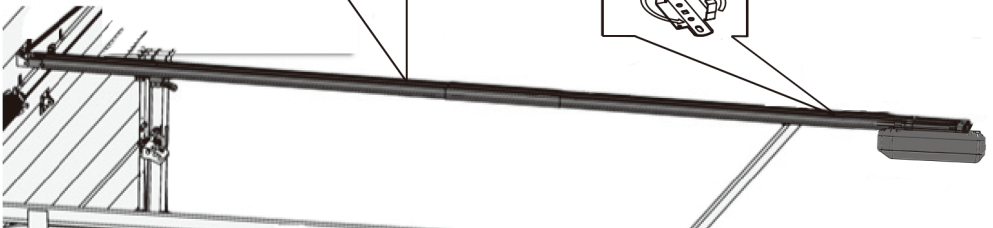
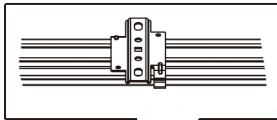

19

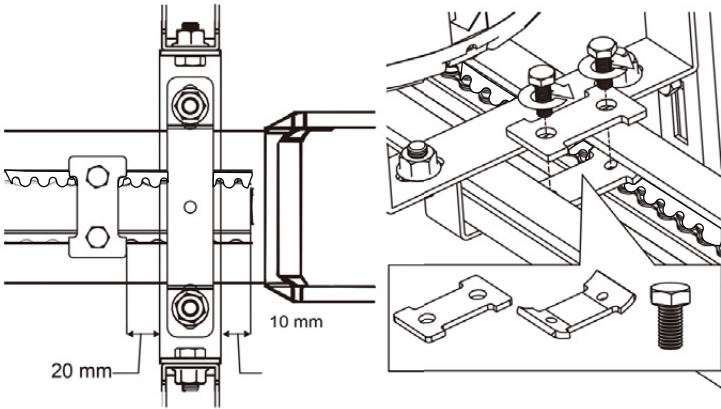

20

$P > 200 \text{ mm}$
 $P < 250 \text{ mm}$

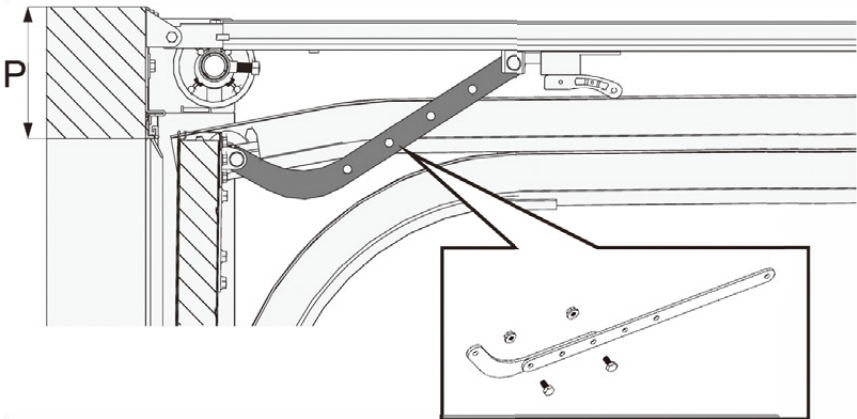

21



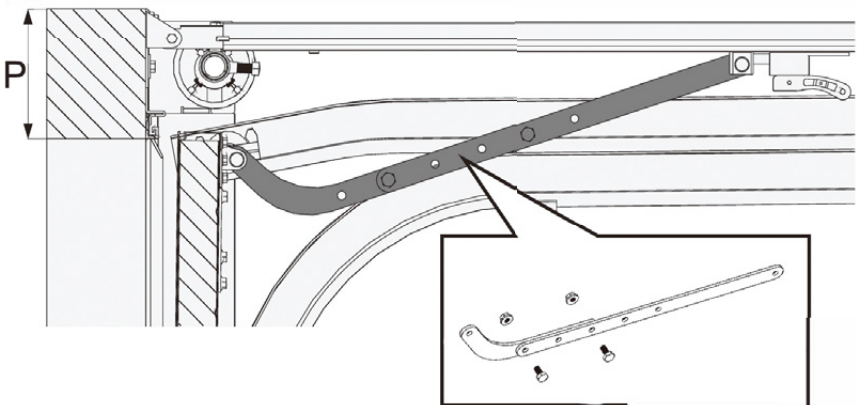

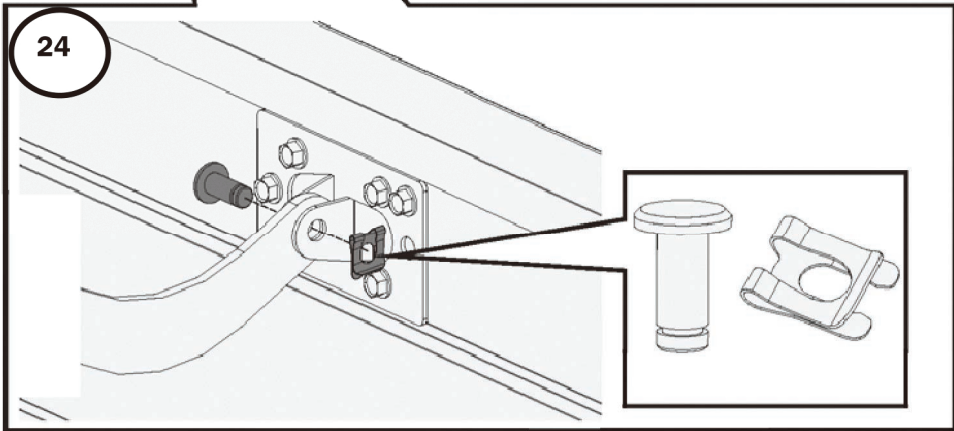
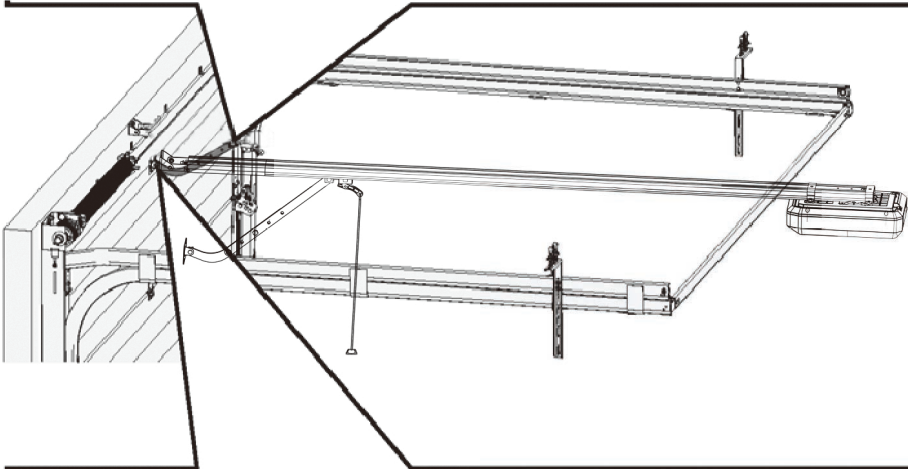
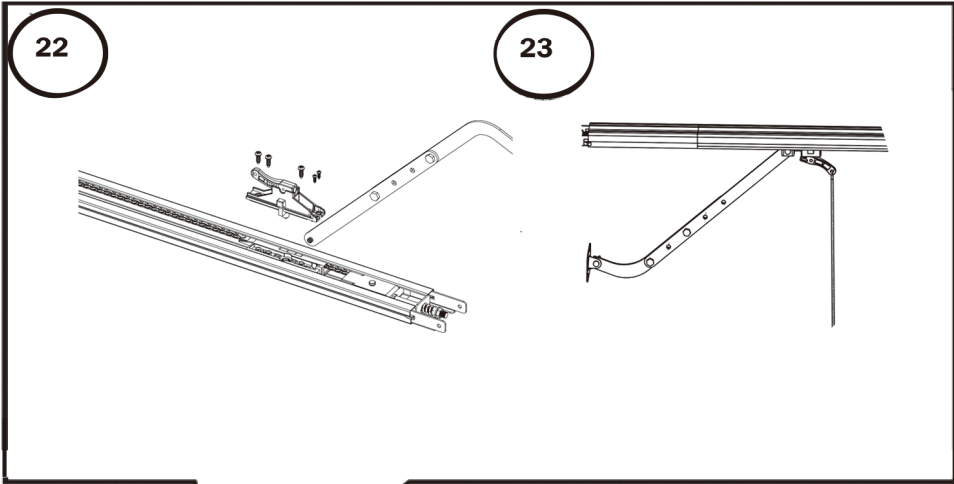
$P > 200 \text{ mm}$
 $P < 300 \text{ mm}$





Før bruk

- Ved førstegangsinstallasjon **må** porten prøves manuelt, før man monterer og programmerer en automatisk portåpner.
- Vær forsiktig når du bruker manuell utløser siden en åpen dør kan falle raskt på grunn av svake eller ødelagte fjærer, eller være ute av balanse. (Firiløs porten ved å trekke i snoren, og kjenn at porten går lett opp/ned, trekk så i friløseren for å låse porten til motorskinnen.)
- Evt. manuell lås må fjernes ved montering av portmotor.
- Plasser portåpneren i et brannsikkert og relativt fuktfritt område som er uten elektromagnetiske forstyrrelser.
- Ikke la barn leke med fjernkontrollene, og oppbevar fjernkontroll(er) utilgjengelig for barn.

Oppstart av portmotoren	
1. Koble til strøm, LED lyset vil lyse i flere sekunder. LED displayet vil vise nummer fra 99 til 11. Motoren går til standby-modus	 
2. Standby modus "- -"	
3. Åpne døren manuelt til den låses i trekkvognen, du vil høre et klikk. Sørg for at porten er lukket før du programmerer (se pkt. 4)	
4. Når porten er koblet til trekkvognen, hold inne  til porten er helt lukket.	

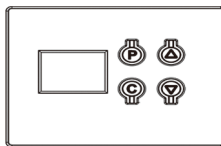









Portmotoren programmeres ved bruk av knappene på kontrollpanelet





Åpne/lukke ved bruk av impuls signal fra håndsenderen. Det er flere knapper på håndsenderen for mulighet å styre flere portmotorer.

Programmere åpne/lukke posisjoner

1. Trykk og hold "P" til displayet viser "P1"	
2. Trykk "P" og displayet viser "OP" (open). Nå kan vi programmere portens åpen-posisjon.	
3. Trykk og hold inne  , displayet blinker "OP"	
4. Når porten er kjørt til godkjent Åpen-posisjon. bekreft ved å trykke en gang på "P", displayet viser "CL" (close)	
5. Trykk og hold inne  , displayet blinker "CL". Når porten er lukket, bekreft ved å trykke en gang på "p".	
6. Porten vil kjøre en automatisk selv-test av posisjonene og automatisk stille inn motstandstyrken den trenger for jevn gange.	
7. Om innstillingene er godkjent vil displayet gå tilbake til standby-modus.	

Om programmeringen var vellykket vil håndsenderene nå fungere, da de er pre-programmert til hver portmotor.

Programmere ekstra trådløse sendere

1. Trykk en gang på "C". Displayet viser "Su"	
2. Trykk to ganger på knappen du ønsker programmert på senderen. "Su" blinker.	
3. Displayet går tilbake til standby "- -" når senderen er programmert. Gjenta trinnene for å koble til opptil 20 trådløse sendere.	

Fullt minne / slette håndsendere

1. Om det er for mange trådløse sendere program-
mert, vil displayet lyse "Fu".



2. Trykk og hold inne "C", displayet viser "Su"



3. Hold "C" inne i mer enn 8 sekunder, og displayet
blinker "dL". Alle sendere er nå slettet fra minnet.



Justere motstandskraft



1. Trykk og hold inne "P", displayet viser "P1"



2. Trykk én gang på , displayet viser "P2"



3. Trykk én gang på "P", og displayet vil vise innstill-
ingene for motstandskraften.

Trykk  for å øke sensitiviteten, og  for å
redusere den.

Maksimum F9 og minimum F1.

Standard er F5



Programmere fotocelle



1. Trykk og hold inne "P", displayet viser "P1"



2. Trykk to ganger på , displayet viser "P3"



3. Trykk én gang på "P", og displayet vil vise innstill-
ingene for fotocelle.

Trykk  til displayet viser "H1", og fotocelle er ak-
tivert. Trykk  til displayet viser "H0" og fotocelle
er deaktivert.







Trykk "P" for å bekrefte og avslutte.









*Om fotocelle ikke er fysisk tilkoblet må den stå på
"H0", ellers vil porten kun gå opp.*

Automatisk lukking

(Skal kun benyttes ved tilkoblet fotocelle)

- | | |
|--|---|
| 1. Trykk og hold inne "P" til displayet viser "P1" |  |
| 2. Trykk tre ganger på  , displayet viser "P4" |  |
| 3. Trykk "P" for å se gjeldende innstilling. Trykk  for å øke tiden med 1 minutt og  redusere med 1 minutt.
Maksimum er "b9" (9 min.) og minimum er "b0" (Av) |  |







Tastelås funksjon

- | | |
|--|--|
| 1. Trykk og hold inne "P" til displayet viser "P1" |  |
| 2. Trykk fire ganger på  , displayet viser "P5" |  |
| 3. Trykk "P" for å se gjeldende innstilling. Trykk  display viser "Lc" lås er aktivert. Trykk  display viser "uL" lås er deaktivert. Trykk "P" for å bekrefte innstillingen. | 
 |

Portlås funksjonen deaktiverer mottak av trådløse signaler når porten er lukket. Det må låses opp ved å benytte knappen på en av de 2 medfølgende håndsenderene.



Kraftinnstilling

- | | |
|--|--|
| 1. Trykk og hold inne "P" til displayet viser "P1" |  |
| 2. Trykk på  , til displayet viser "P6".
Trykk "P" for å se gjeldende innstilling. |  |
| 3. Trykk  eller  for å justere innstillingene.
Desto høyere "F", desto sterkere blir kraften på portmotoren. Trykk "P" for å lagre. | 
 |

Tilkobling av valgfritt tilbehør

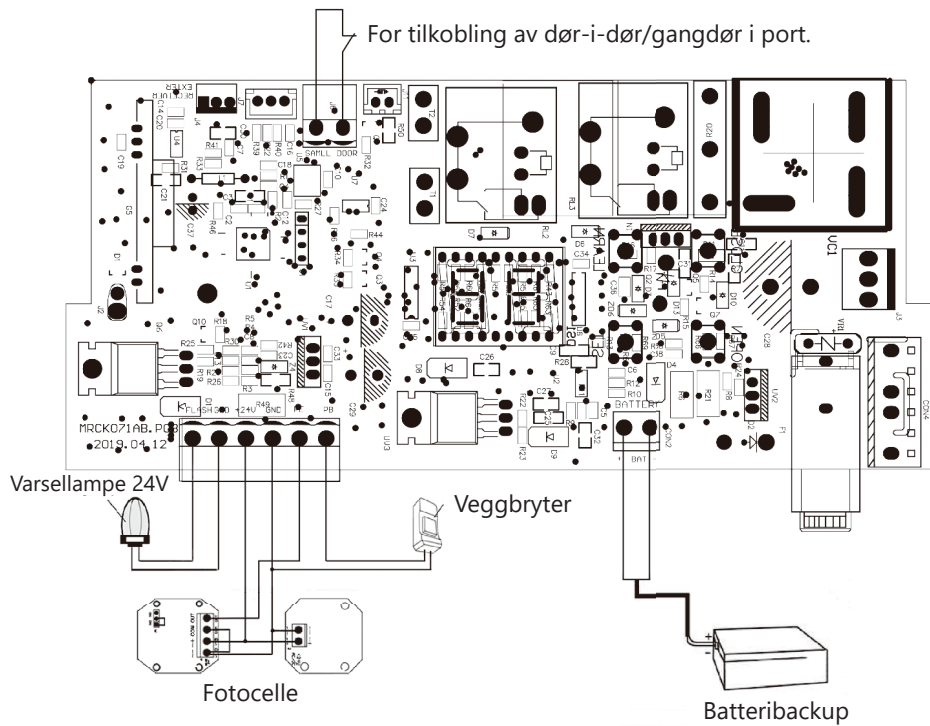

Tilkobling av veggbryter eller nøkkelbryter på PB og GND

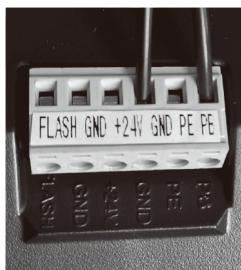

Tilkobling av fotocelle på +24V, GND og PE

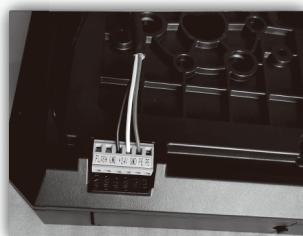

NOTATER:
