

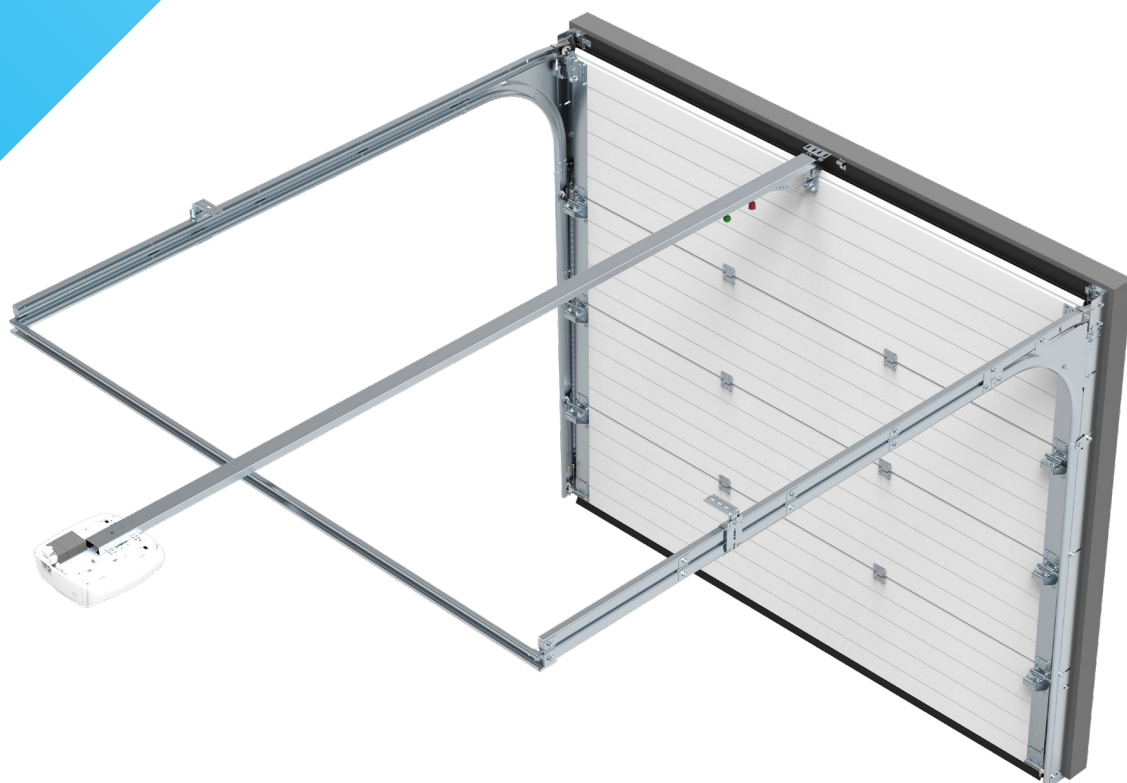

**TS100**

MONTASJEANVISNING

0919



- ✓ EN 12604
- ✓ EN 12453
- ✓ EN 13241

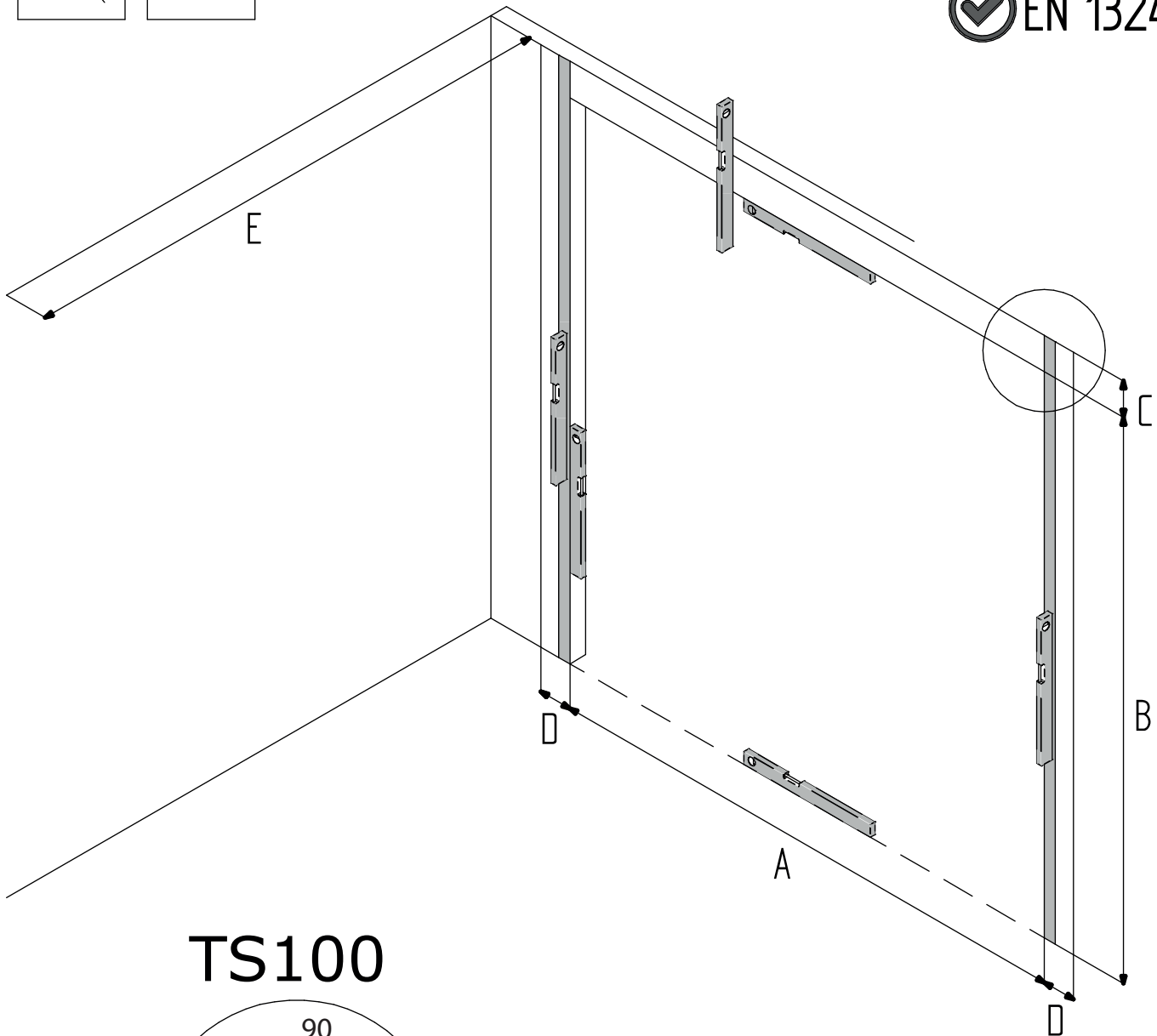
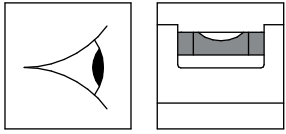

**TS100**

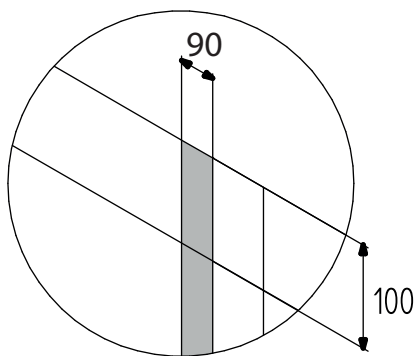

	<b>A</b>	<b>B</b>	<b>C</b>	<b>D</b>	<b>E</b>
	<b>DLW</b>	<b>DLH</b>	<b>FHR</b>	<b>FSR</b>	<b>FMD</b>
<b>NL</b>	Dagmaat breedte	Dagmaat hoogte	Vrije bovenruimte	Vrije zijruimte	Inbouwdiepte
<b>EN</b>	Day Light Width	Day Light Height	Free Head Room	Free Side Room	Free Mounting Depth
<b>DE</b>	Tageslichtbreite	Tageslichthöhe	Sturzfreiraum	Freie Seitenraum	Freie Einbautiefe
<b>FR</b>	Largeur de baie	Hauteur de baie	Linteau disponible	Ecoinçons Requis	Recul
<b>RO</b>	Lățime Gol	Înălțime Gol	Buiandrug Liber	Spațiul Liber Lateral	Spațiul Liber în Adâncime
<b>NO</b>	<b>Lysmål bredde</b>	<b>Lysmål høyde</b>	<b>Fri overhøyde</b>	<b>Sideklaring</b>	<b>Fri monteringsdybde</b>
<b>SE</b>	Dager bredd	Dager höjd	Minsta erforderligt höjdutrymme	Fritt sidoutrymme	Fritt monterings utrymme

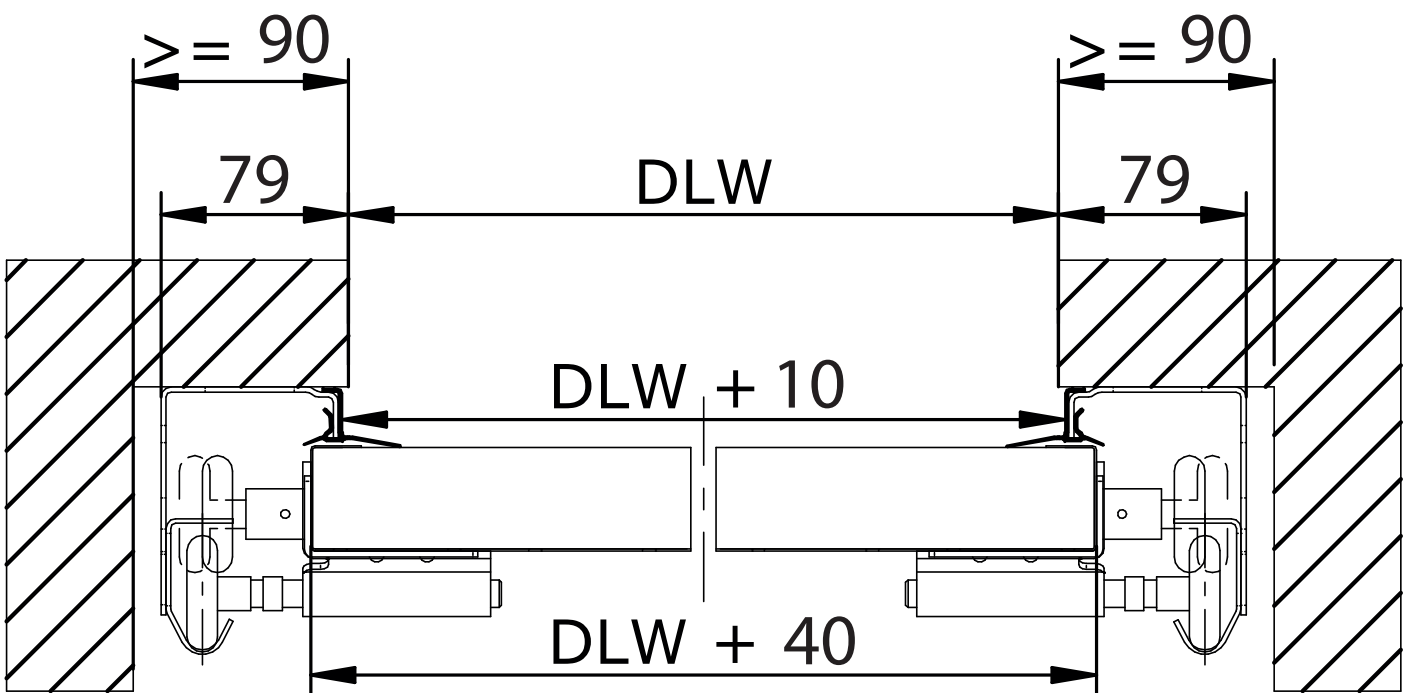
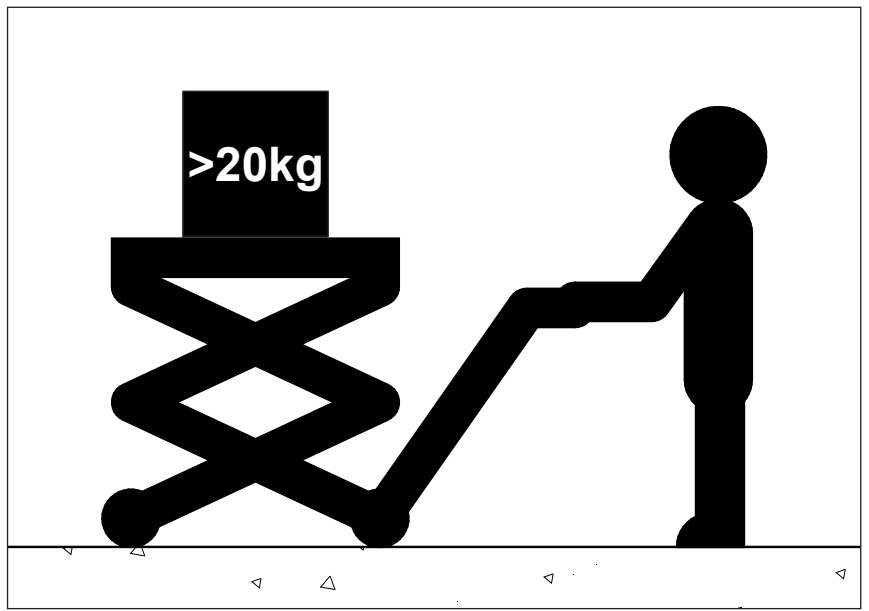
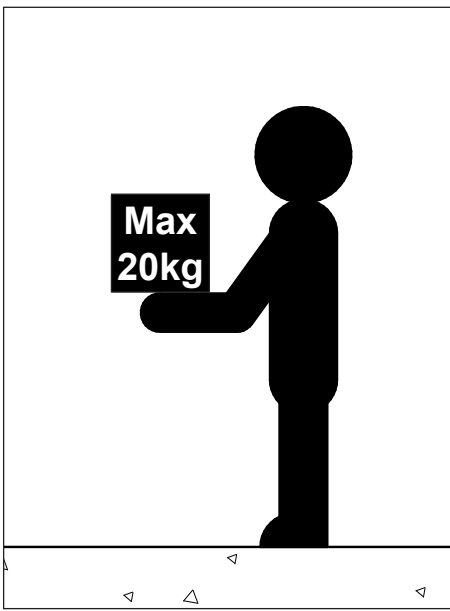

9642



Only remove wing screw after mounting door leaf (without top section).

ATTENTION !!

The springs are pre-tensioned !!

Der Flügelschraube erst nach Torblattmontage (ohne Obere Sektion) entfernen.

ACHTUNG !!

Die Federn haben Vorspannung !!

Enlever la vis à oreilles une fois le tablier (sans la section haute) monté.

ATTENTION !!

Les ressorts sont pré-tendus !!

Vleugelschroef pas verwijderen na montage deurblad (zonder topsectie).

LET OP !!

De veren zijn voorgespannen !!

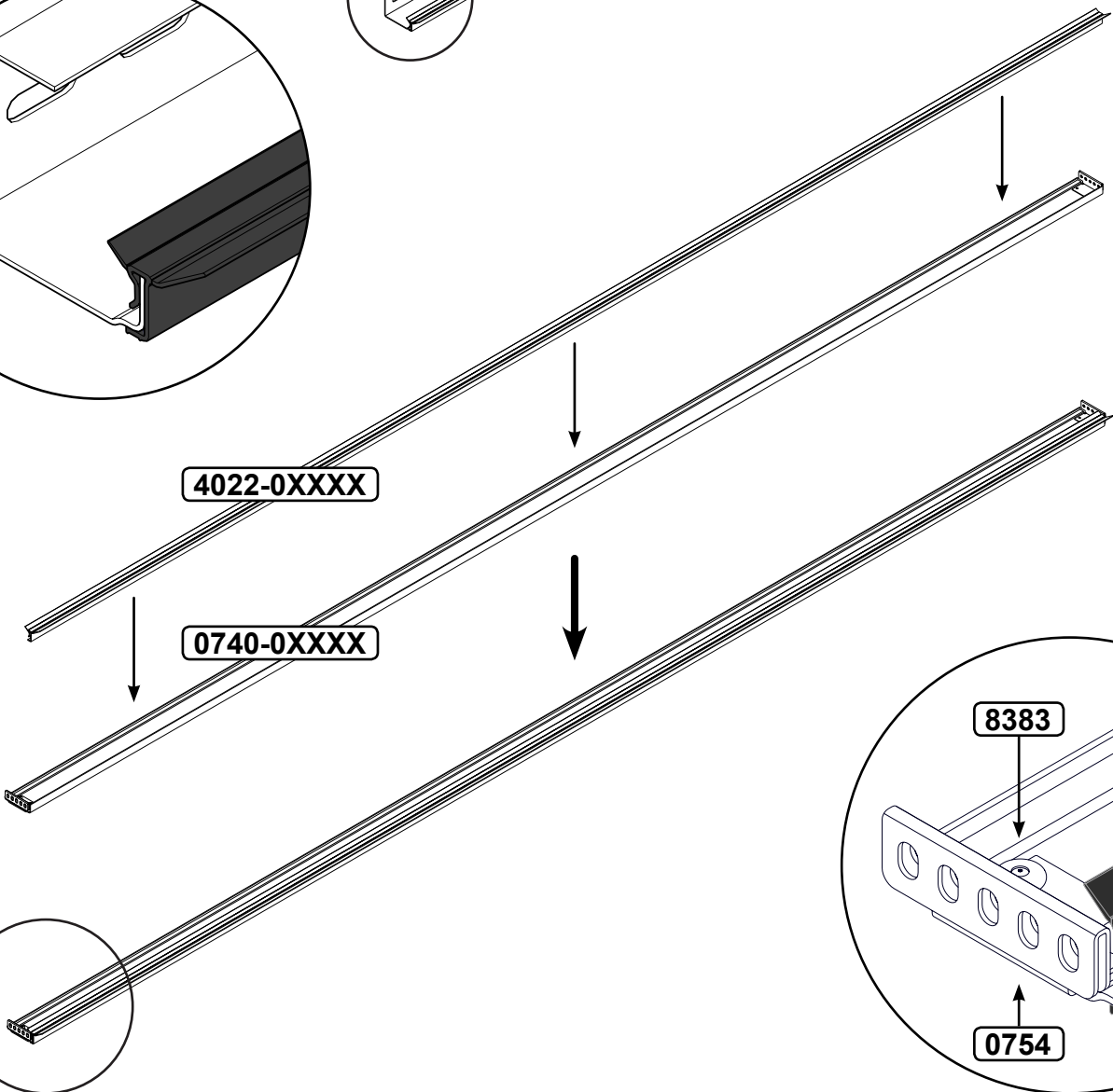
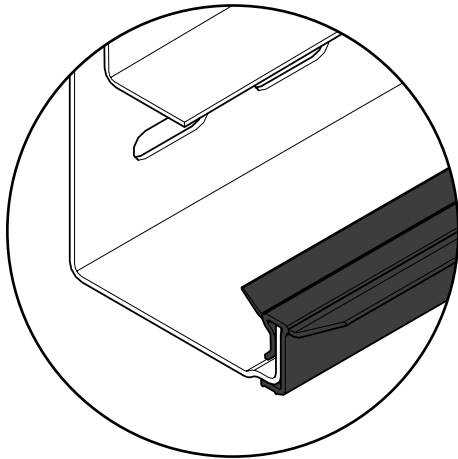
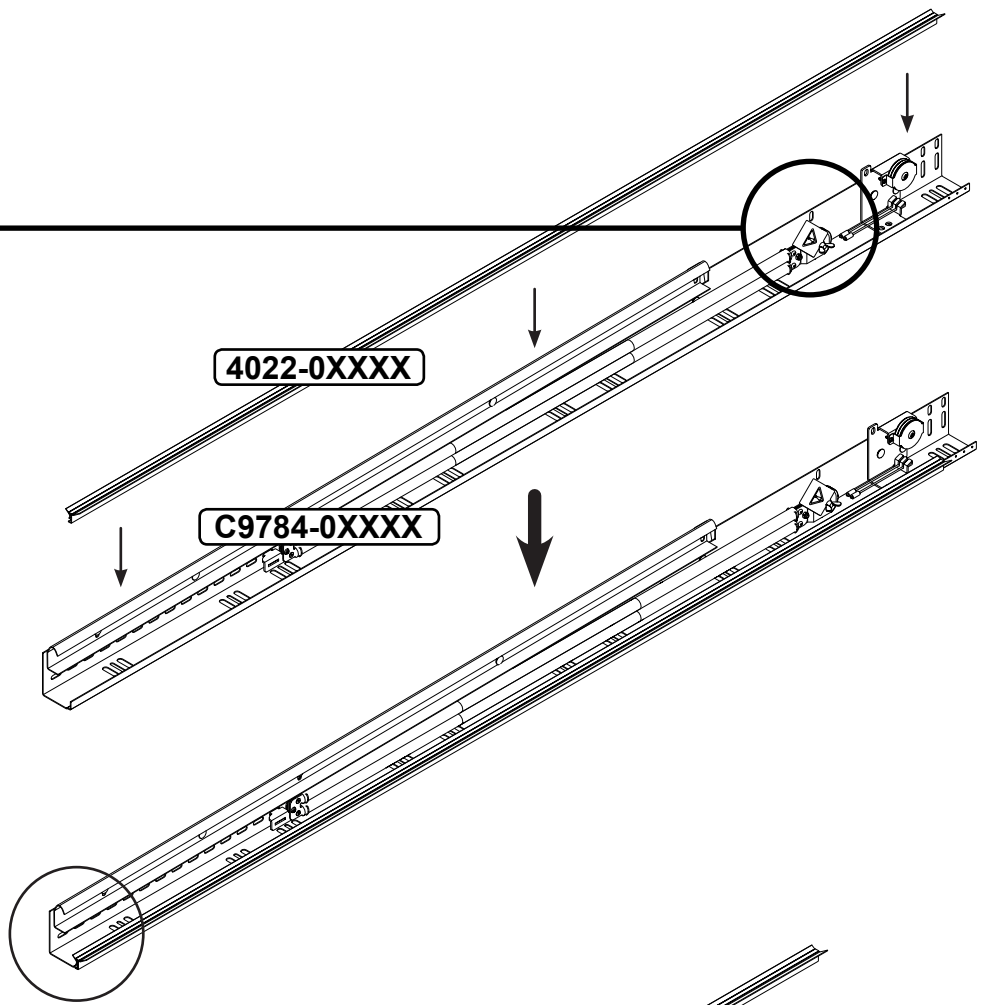

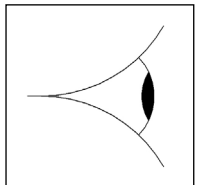
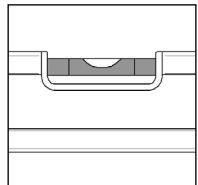
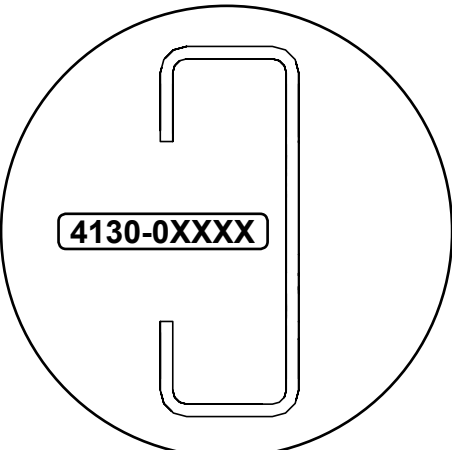
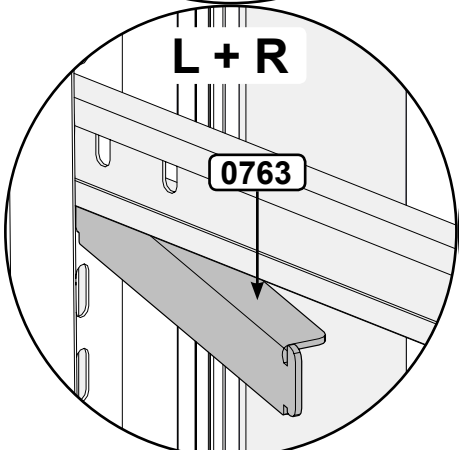
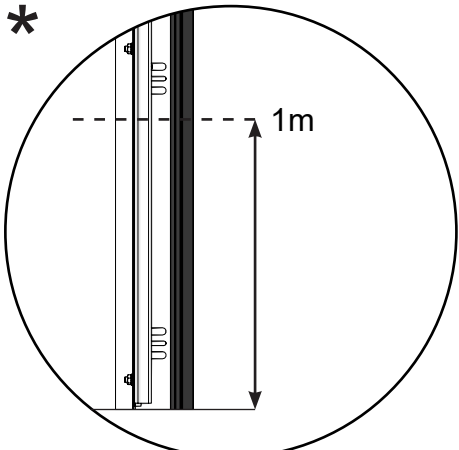
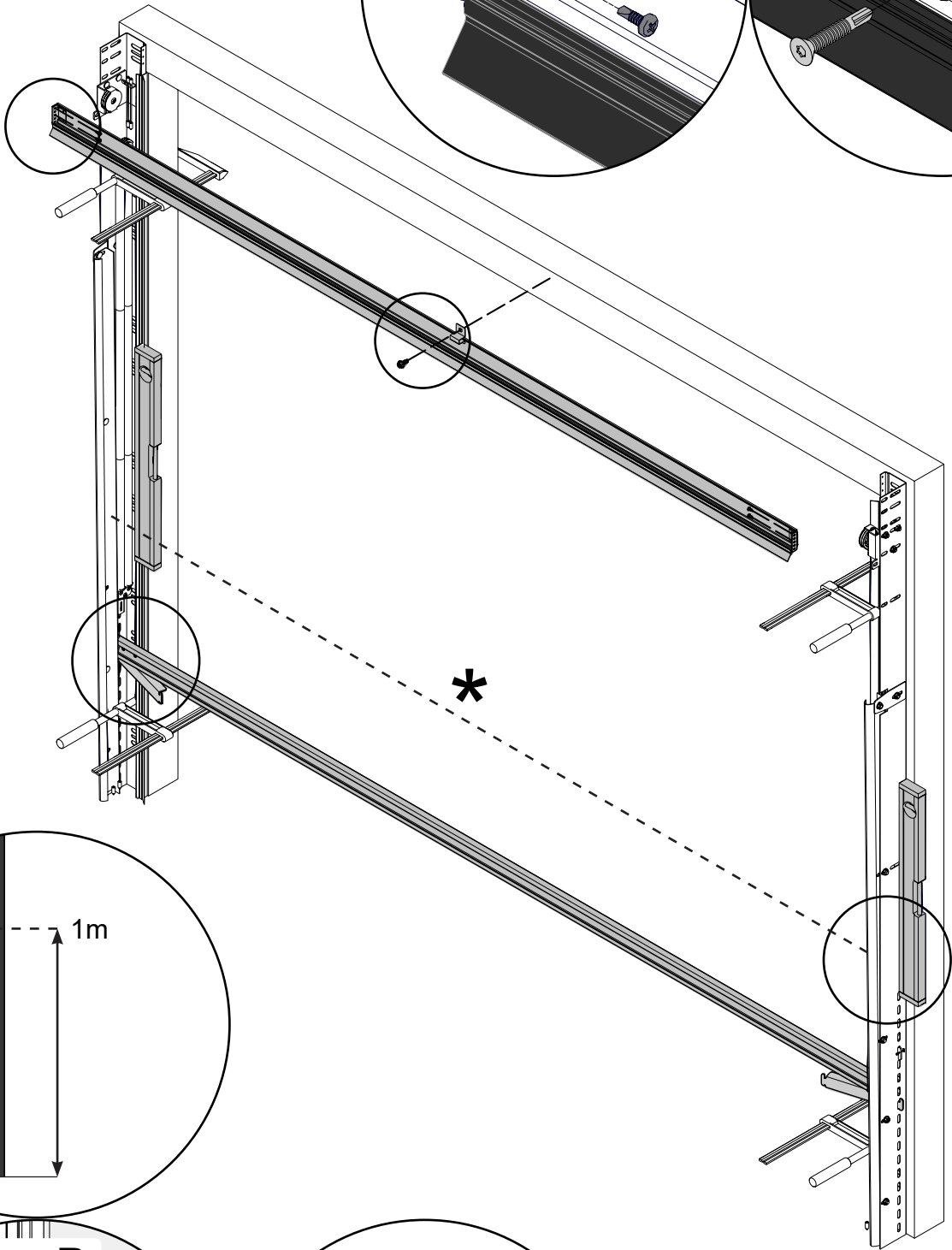
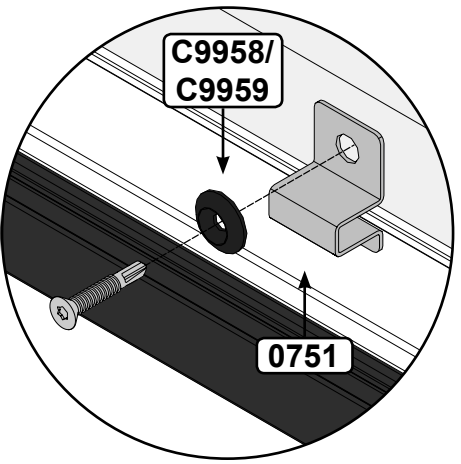
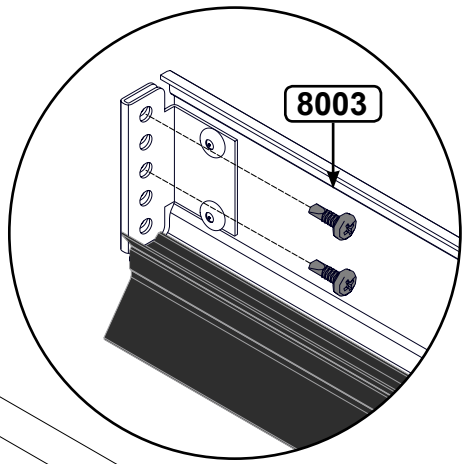
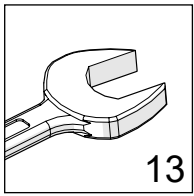

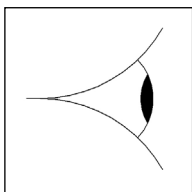
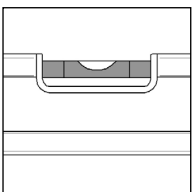
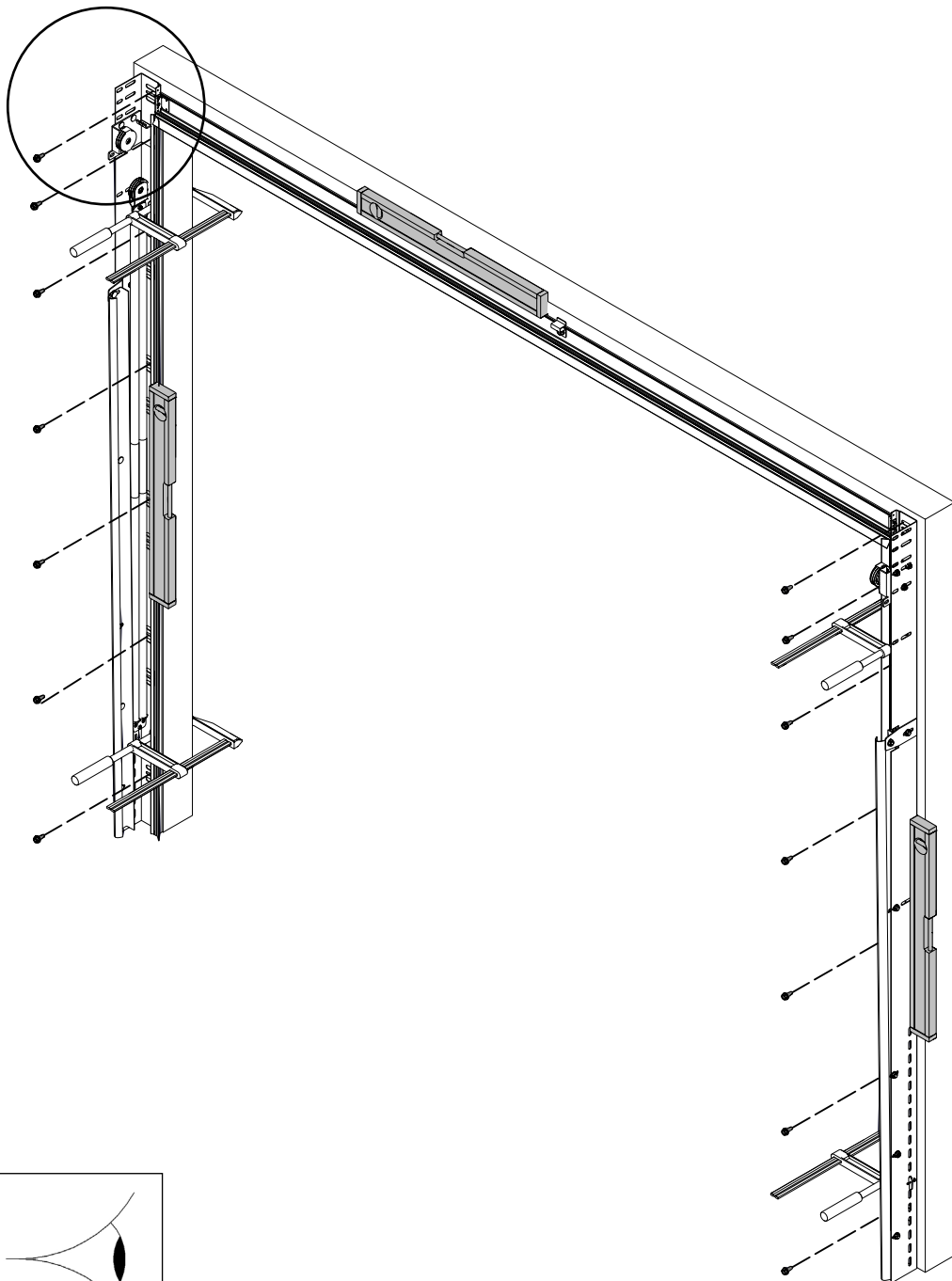
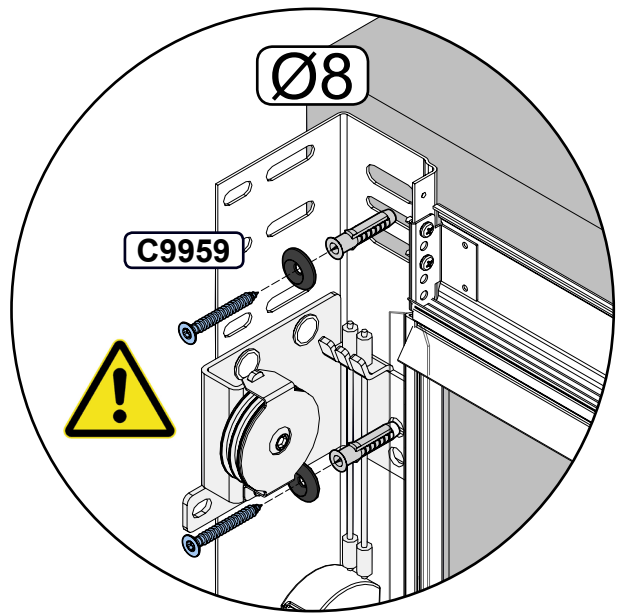
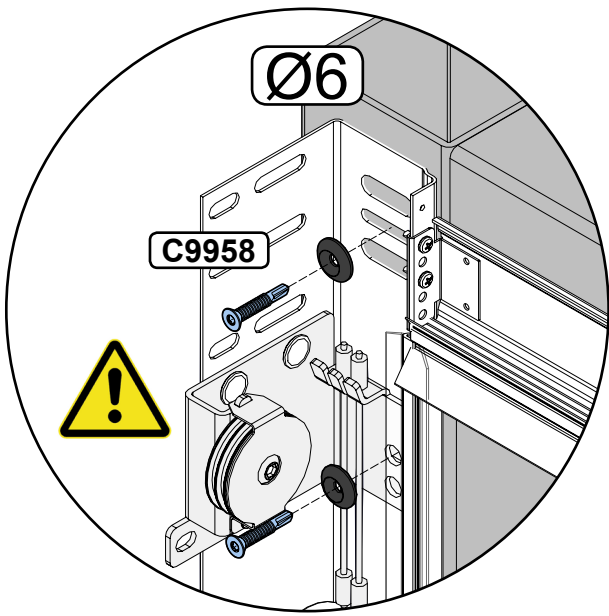

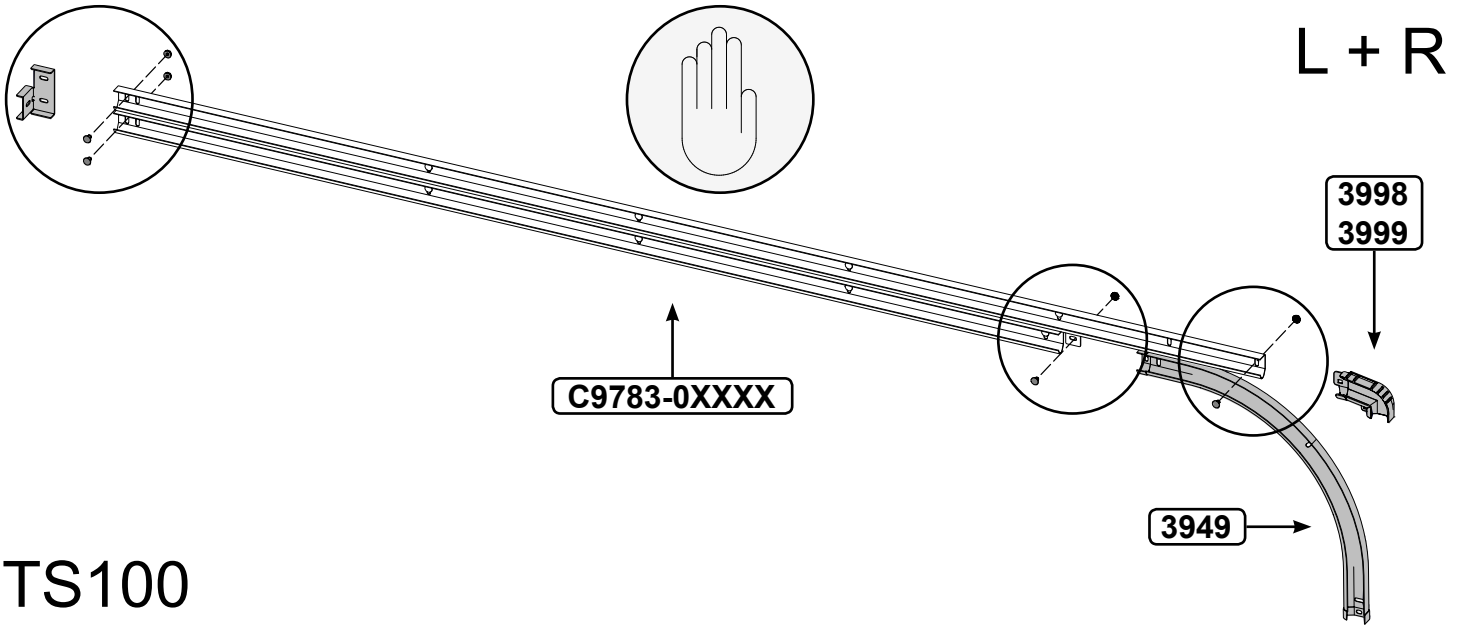

**TS100**

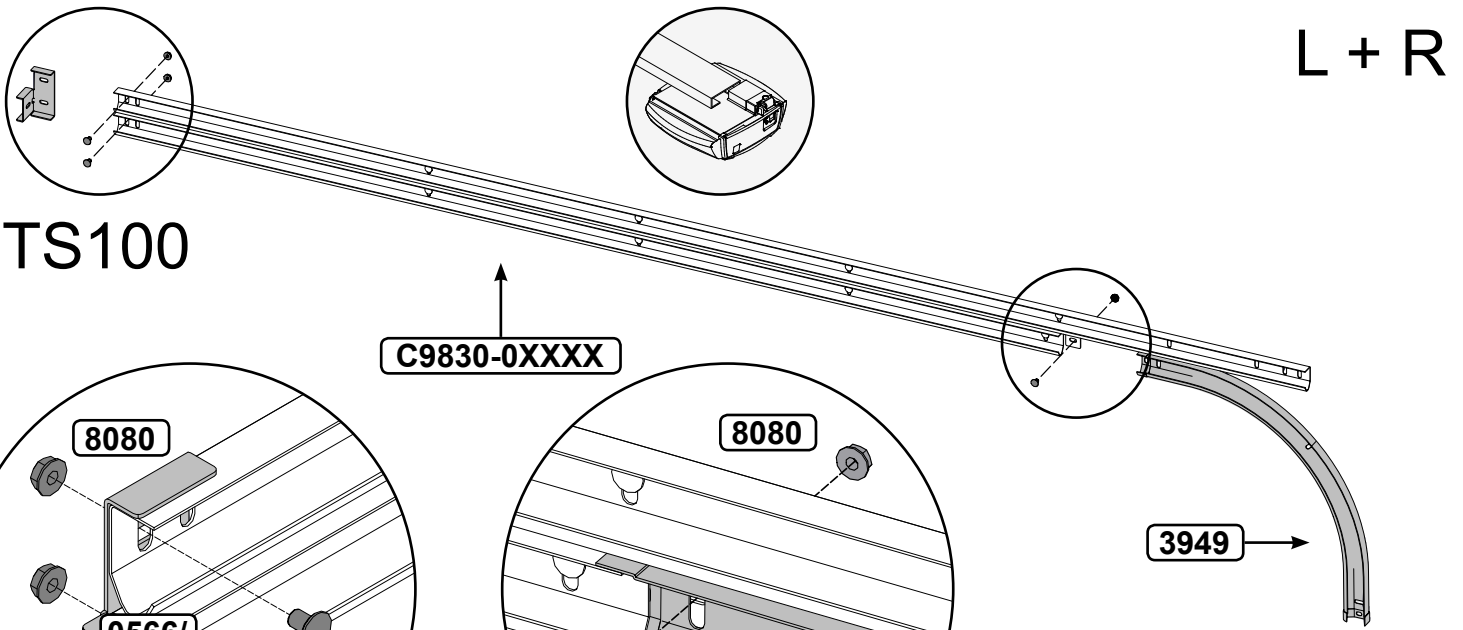
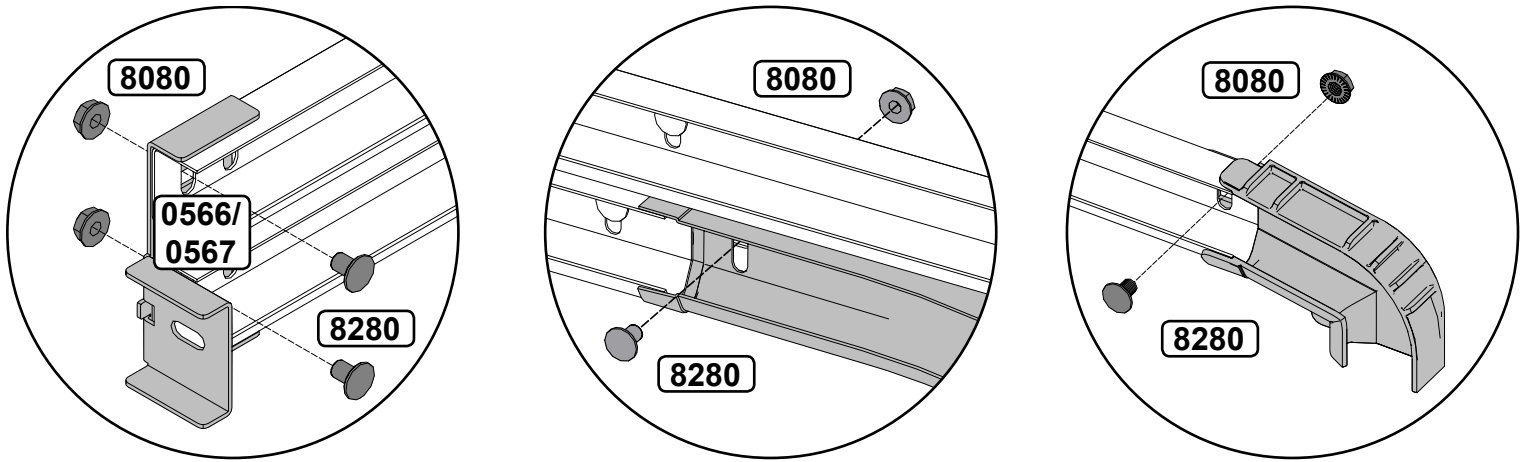

**TS100**

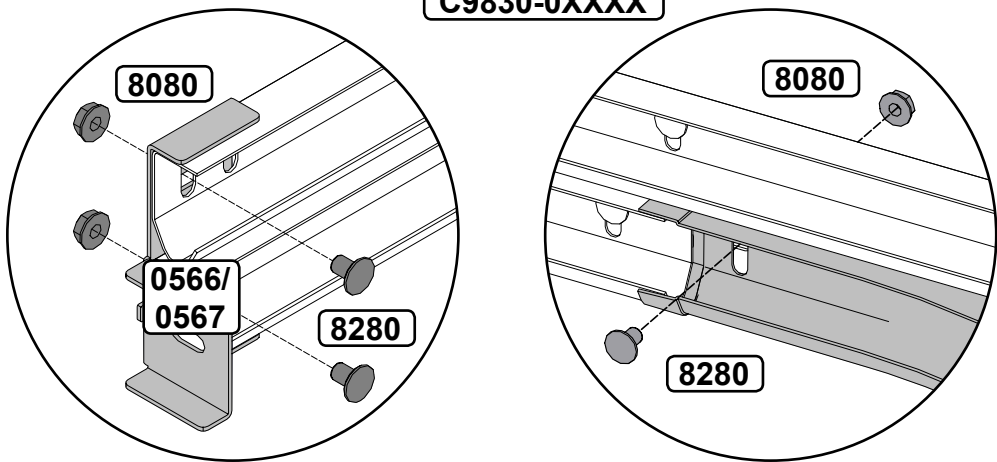



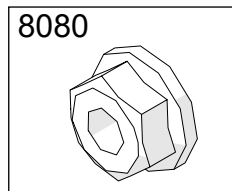
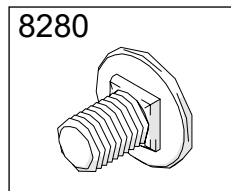
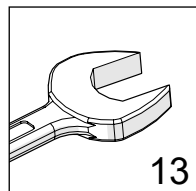
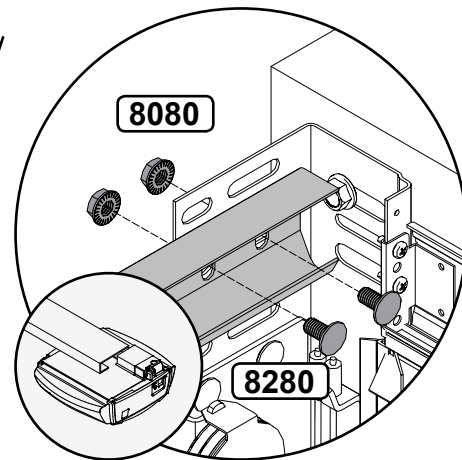
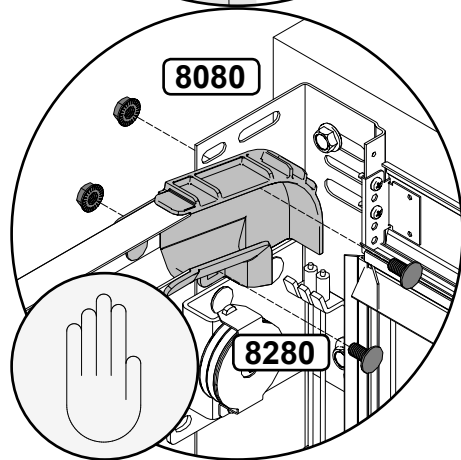
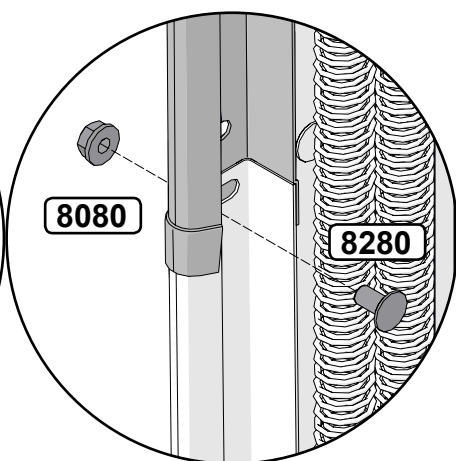
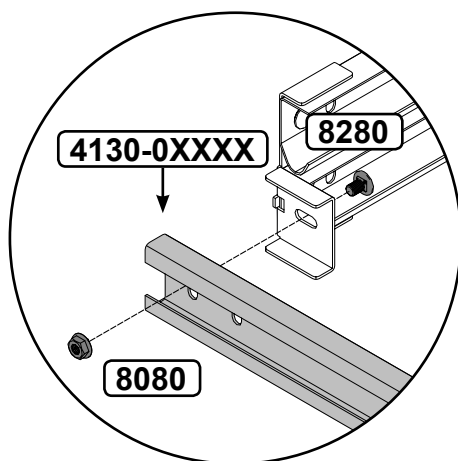
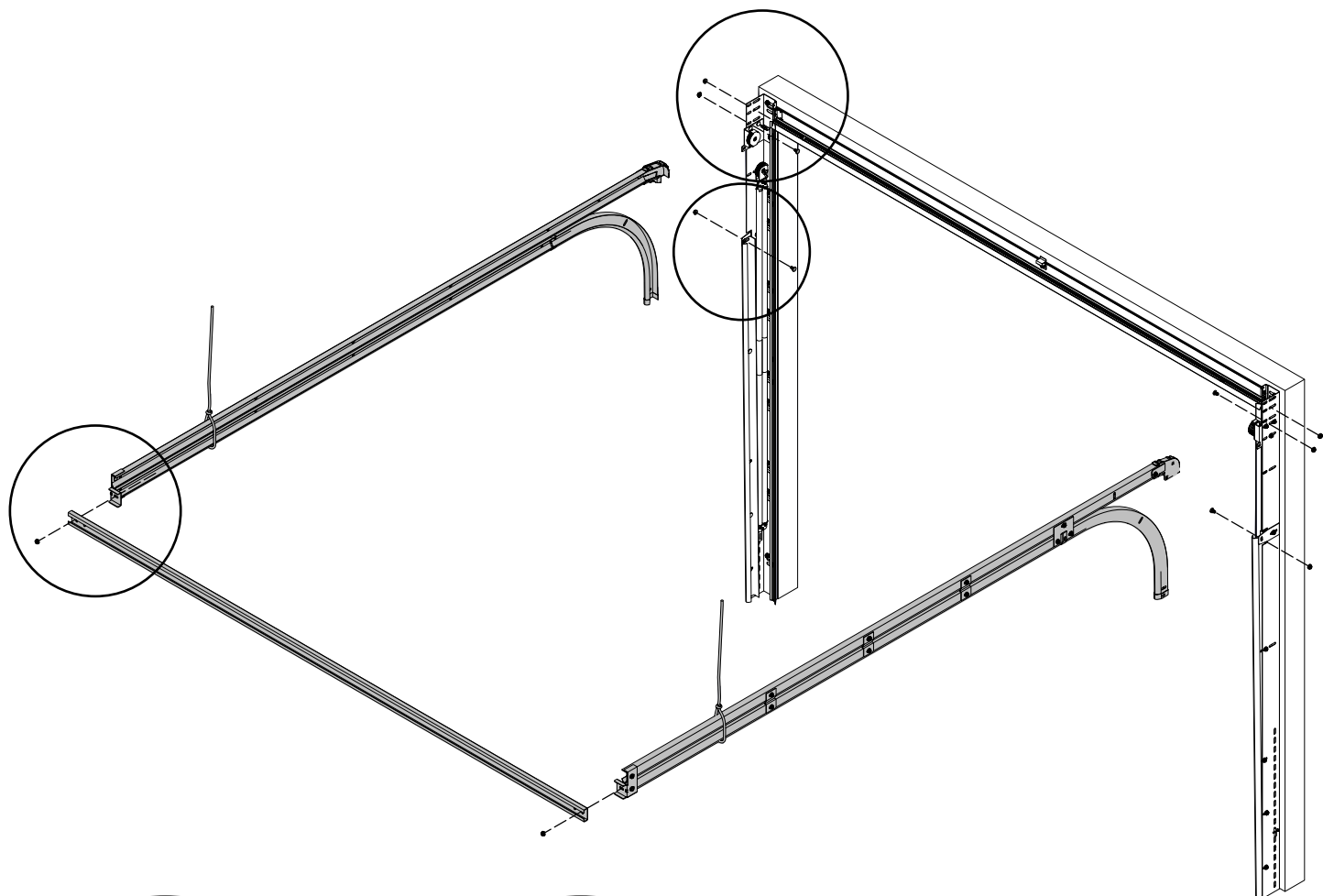



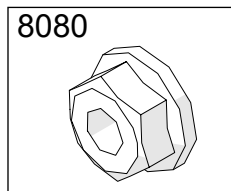
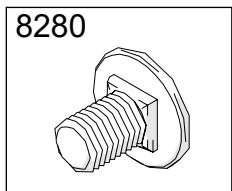
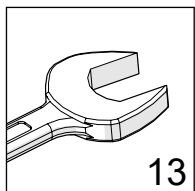
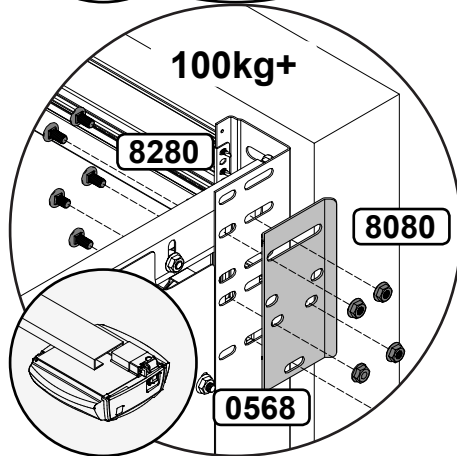
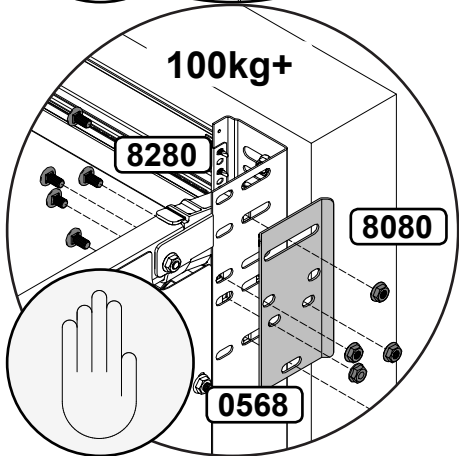
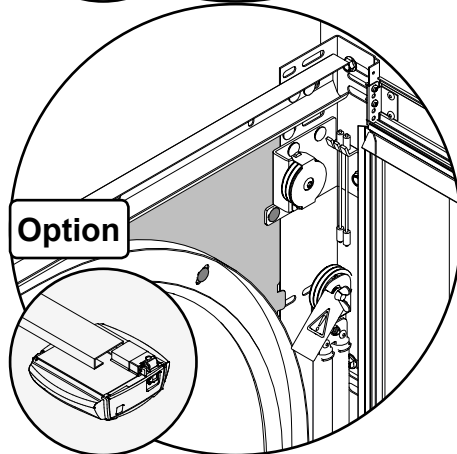
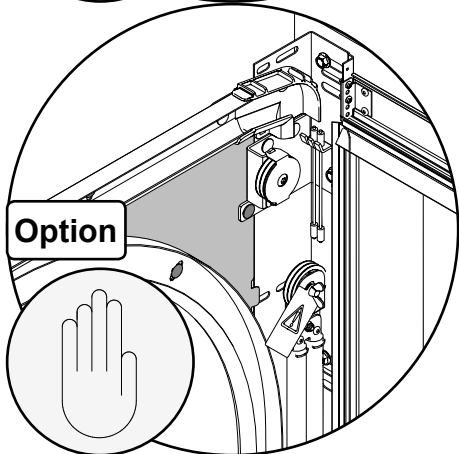
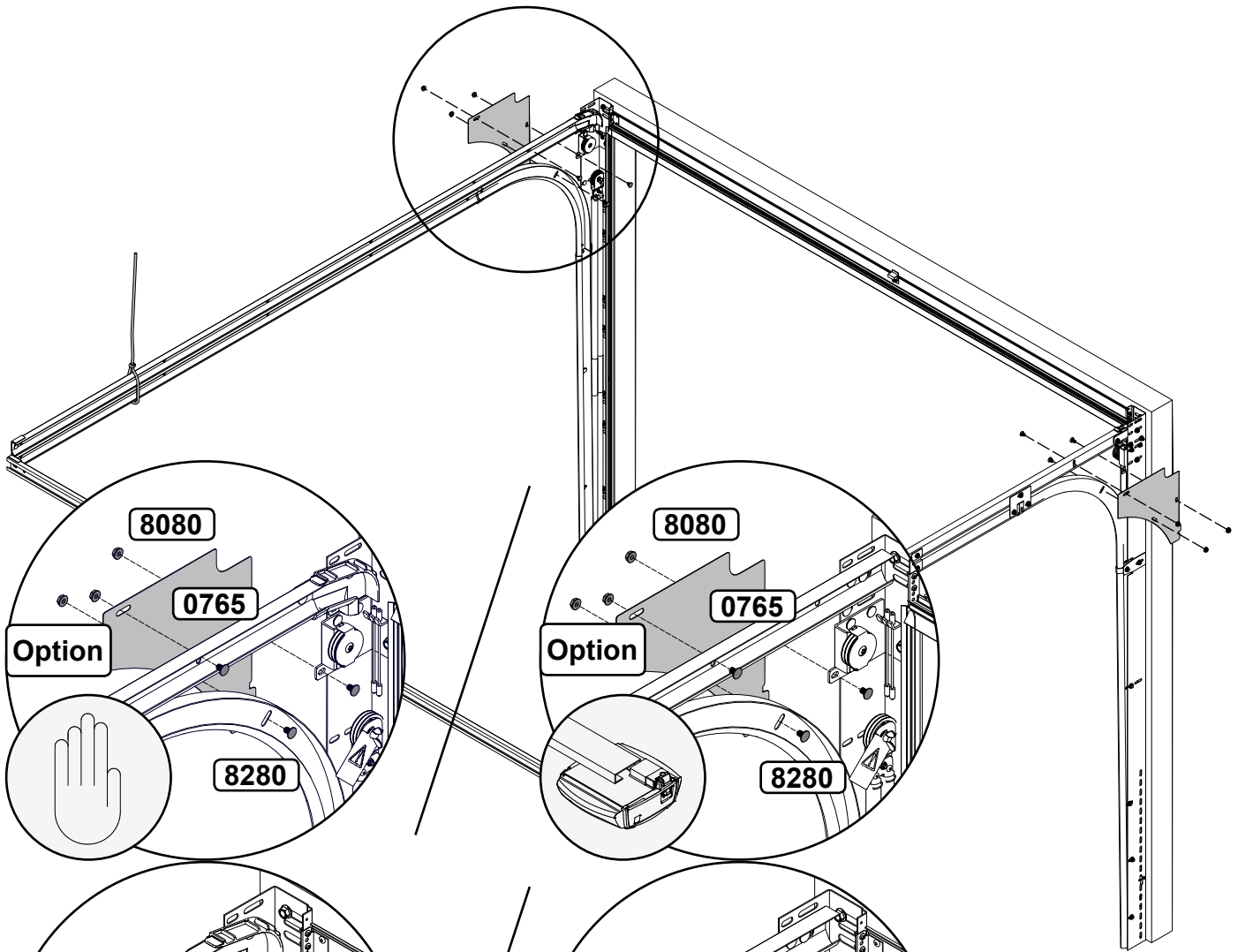

94046

0721

0720

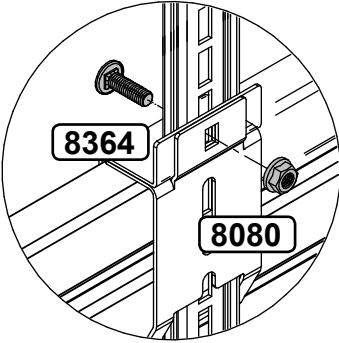
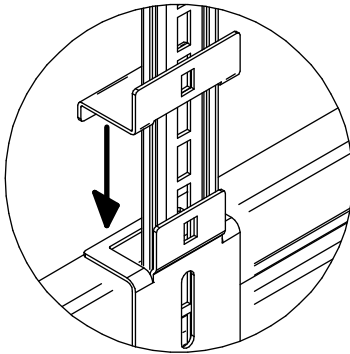

8364

8080

400

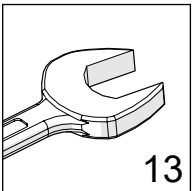

13

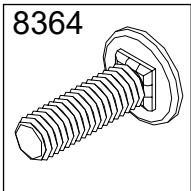

8364

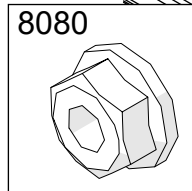

8080

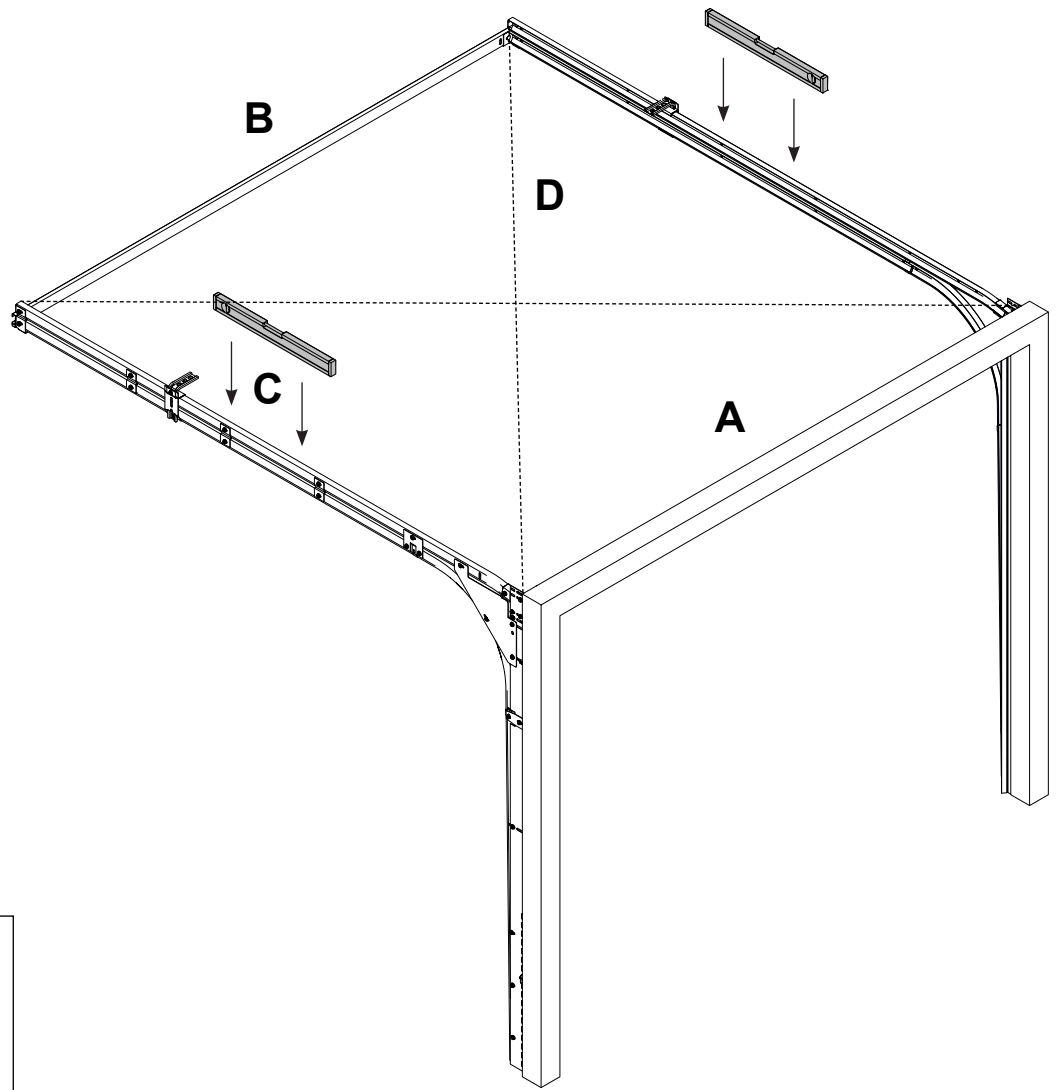

A = B  
C = D

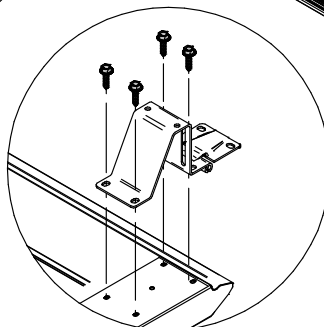
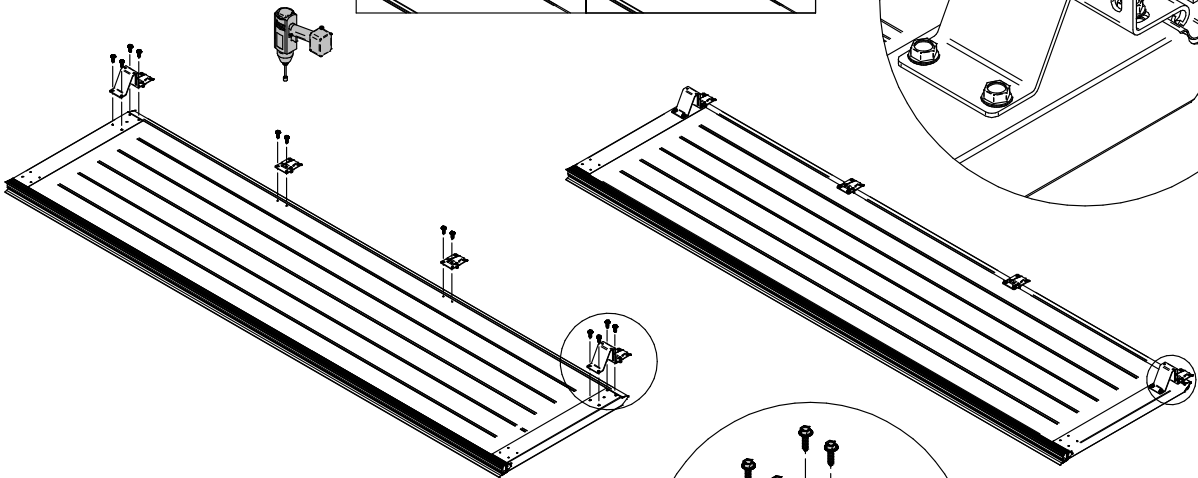
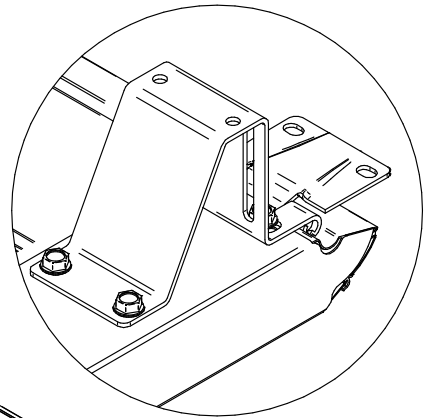
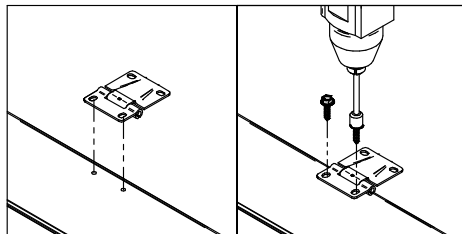
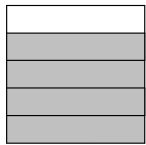
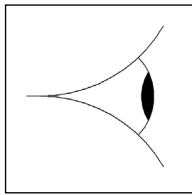
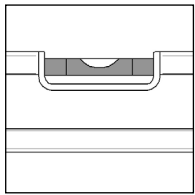
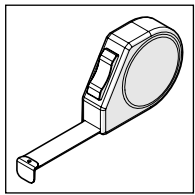

3814 (16mm)/  
3812 (25mm)

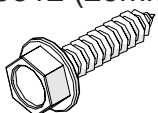

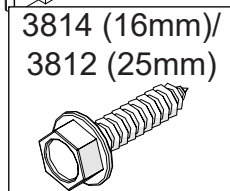
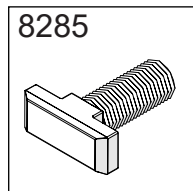
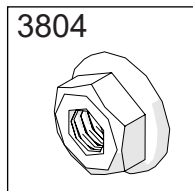
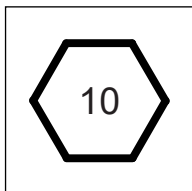
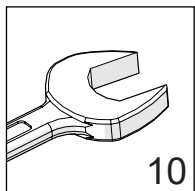
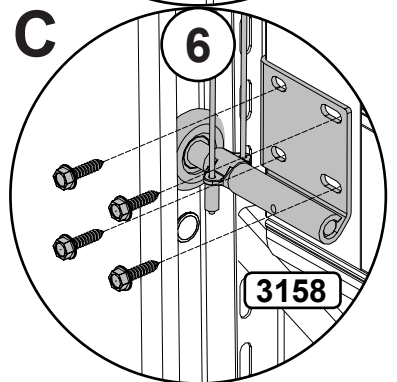
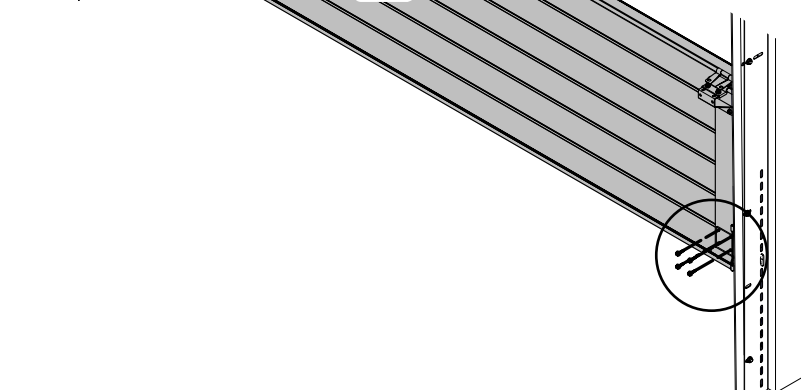
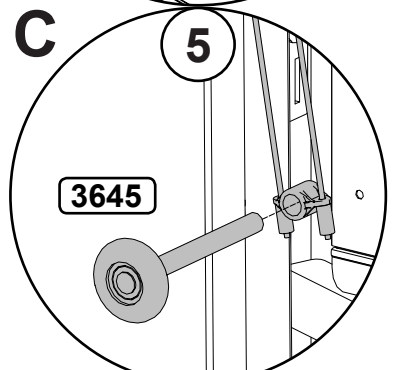
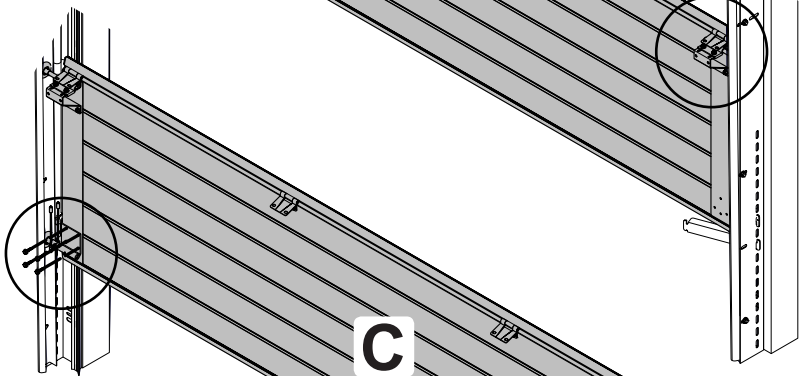
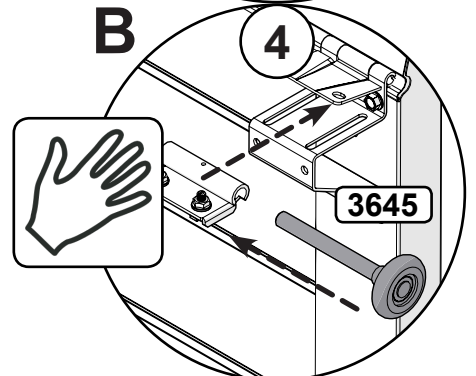
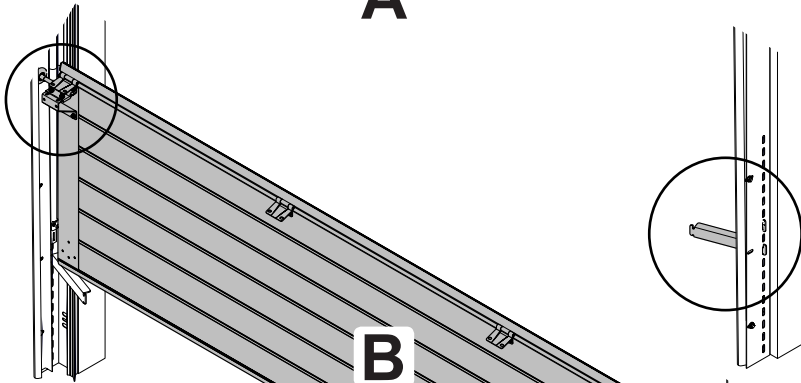
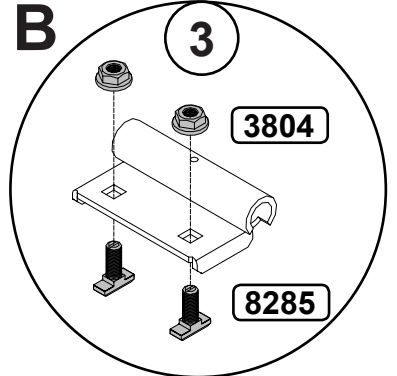
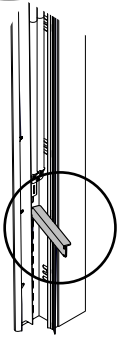
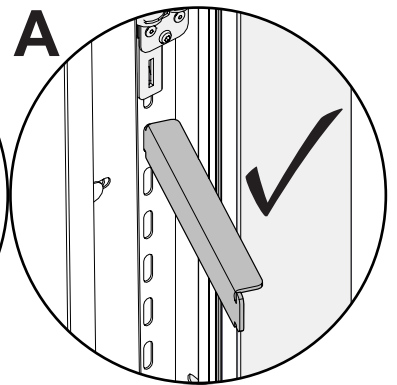
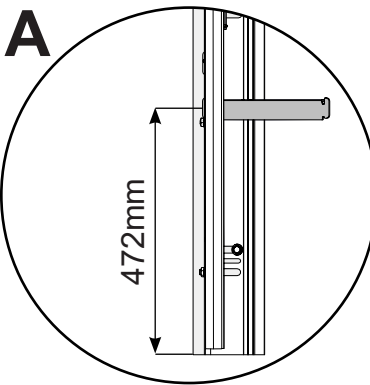
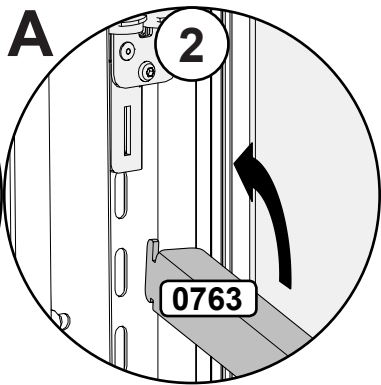
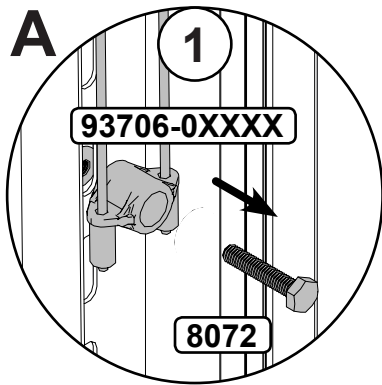

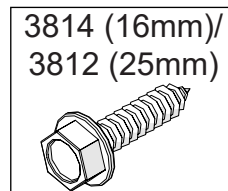
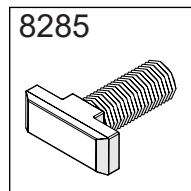
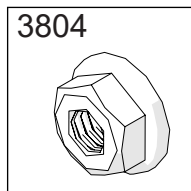
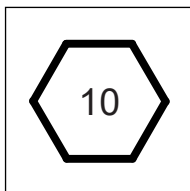
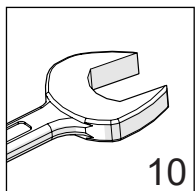
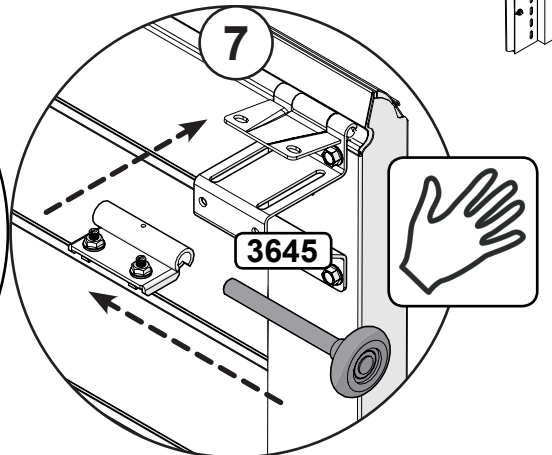
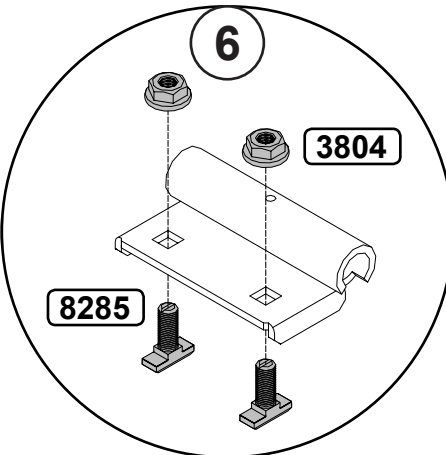
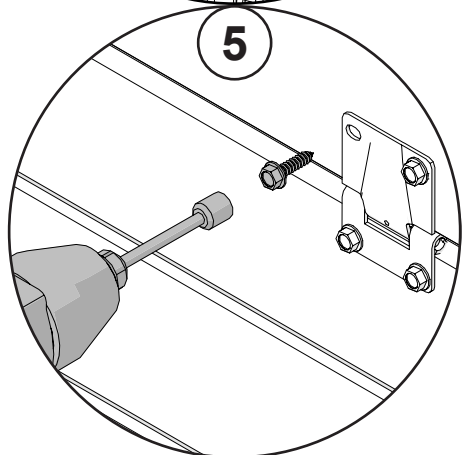
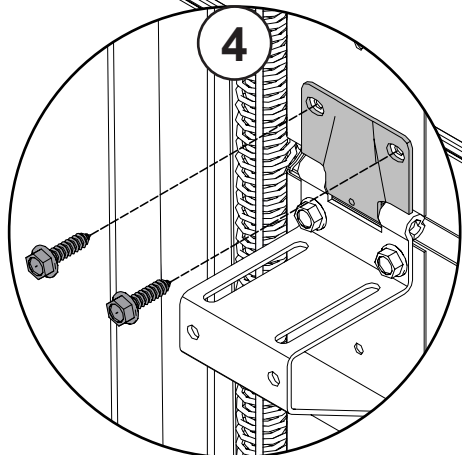
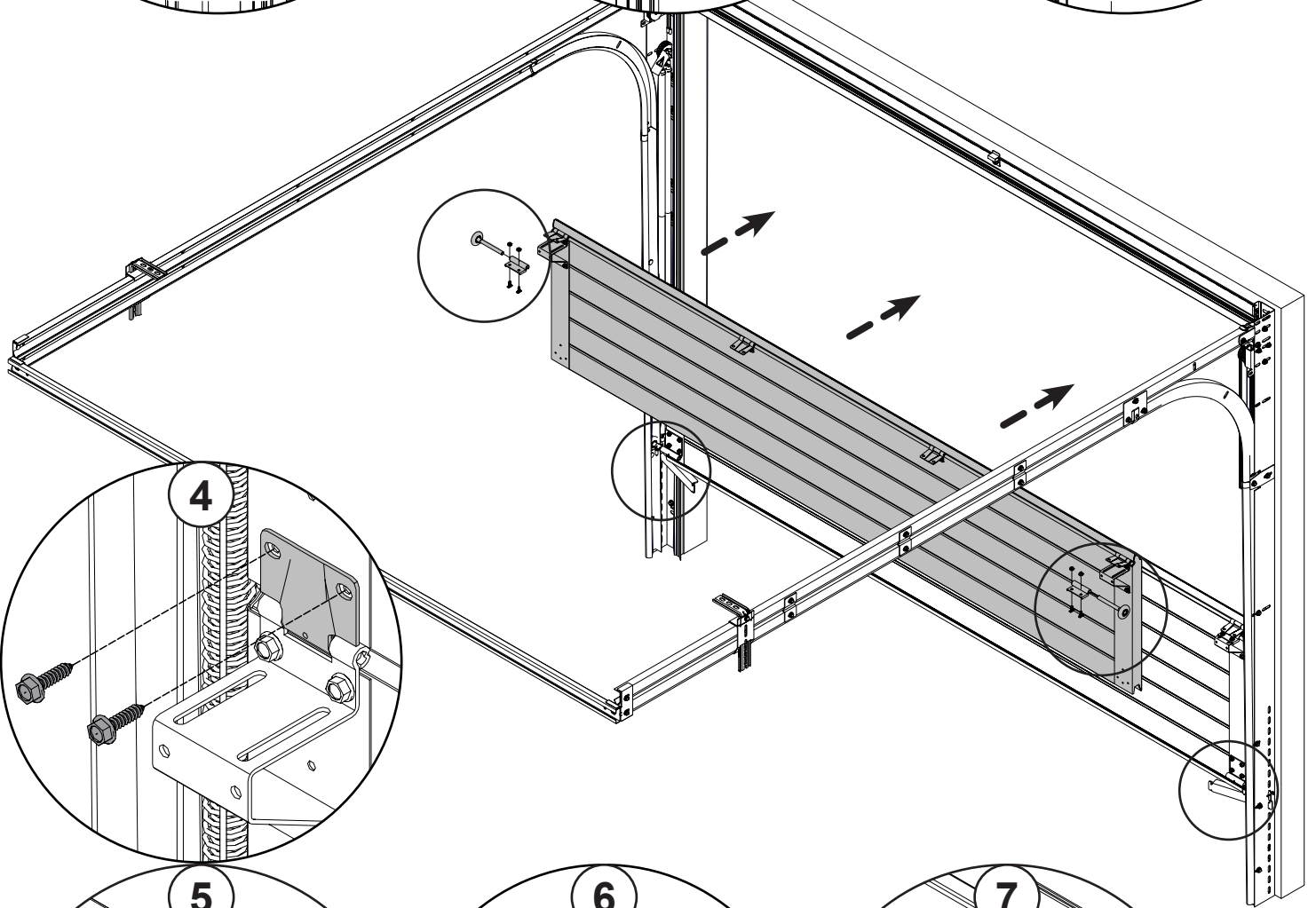
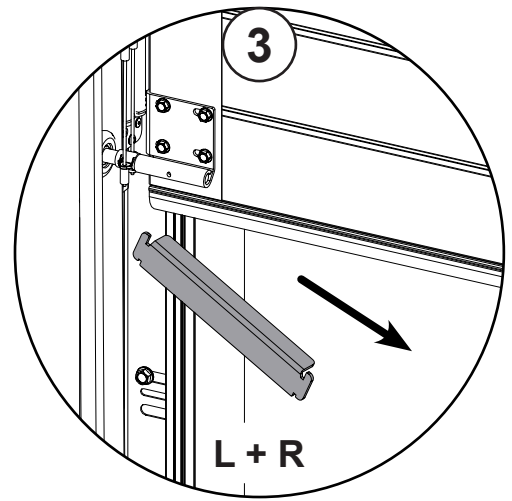
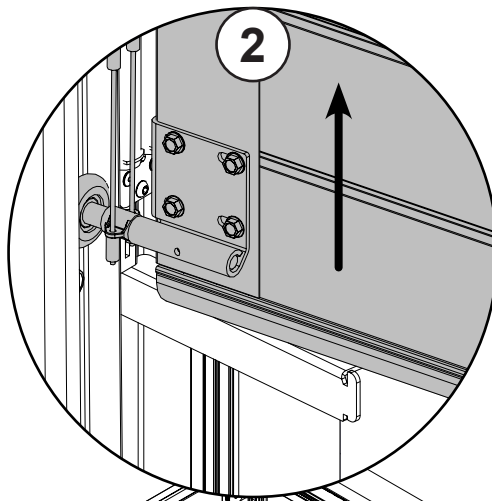
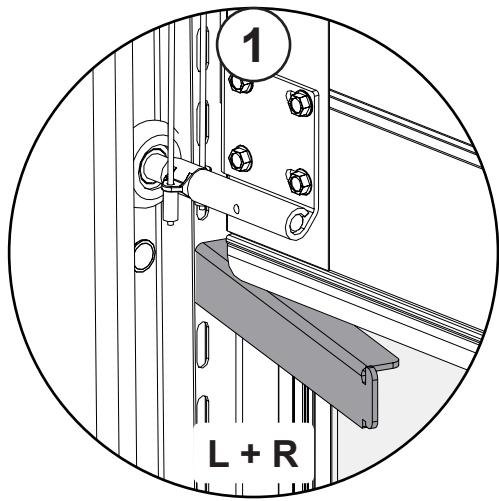



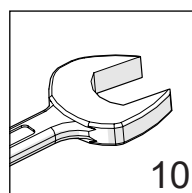
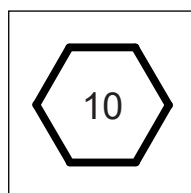
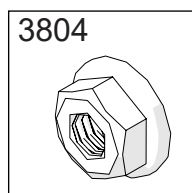
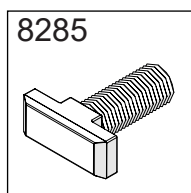
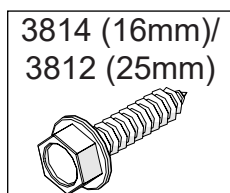
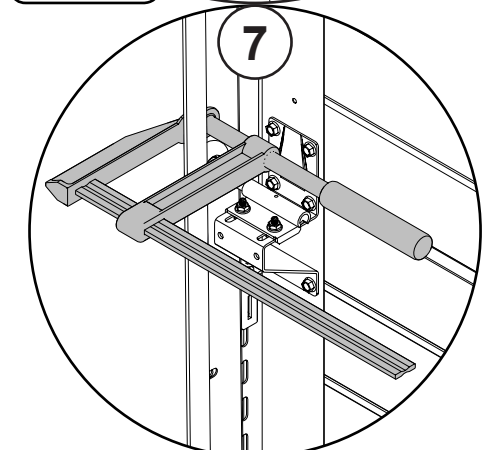
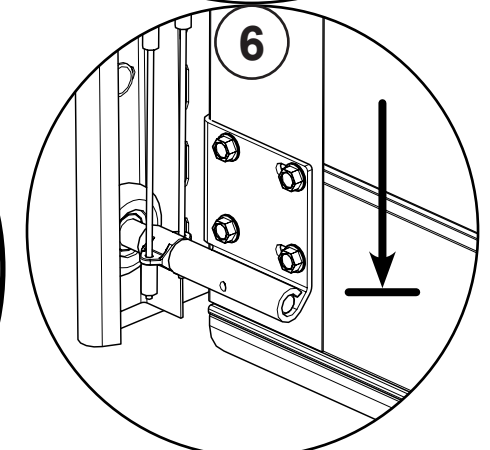
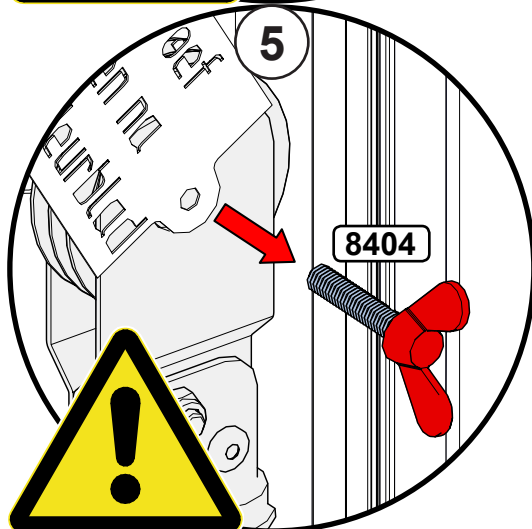
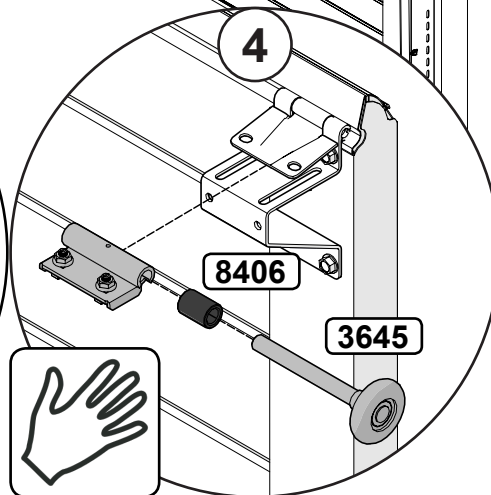
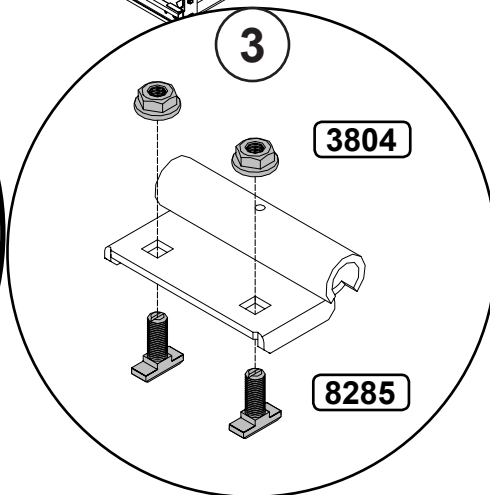
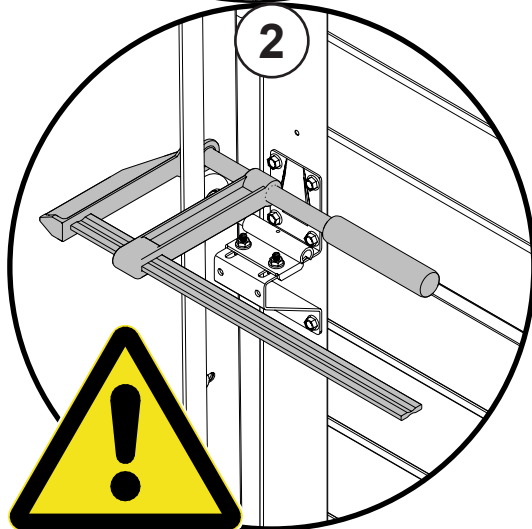
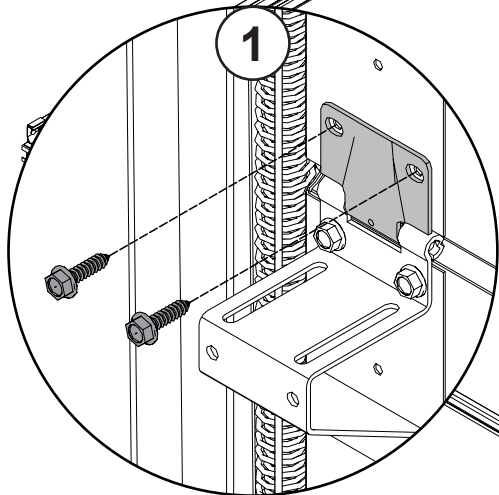
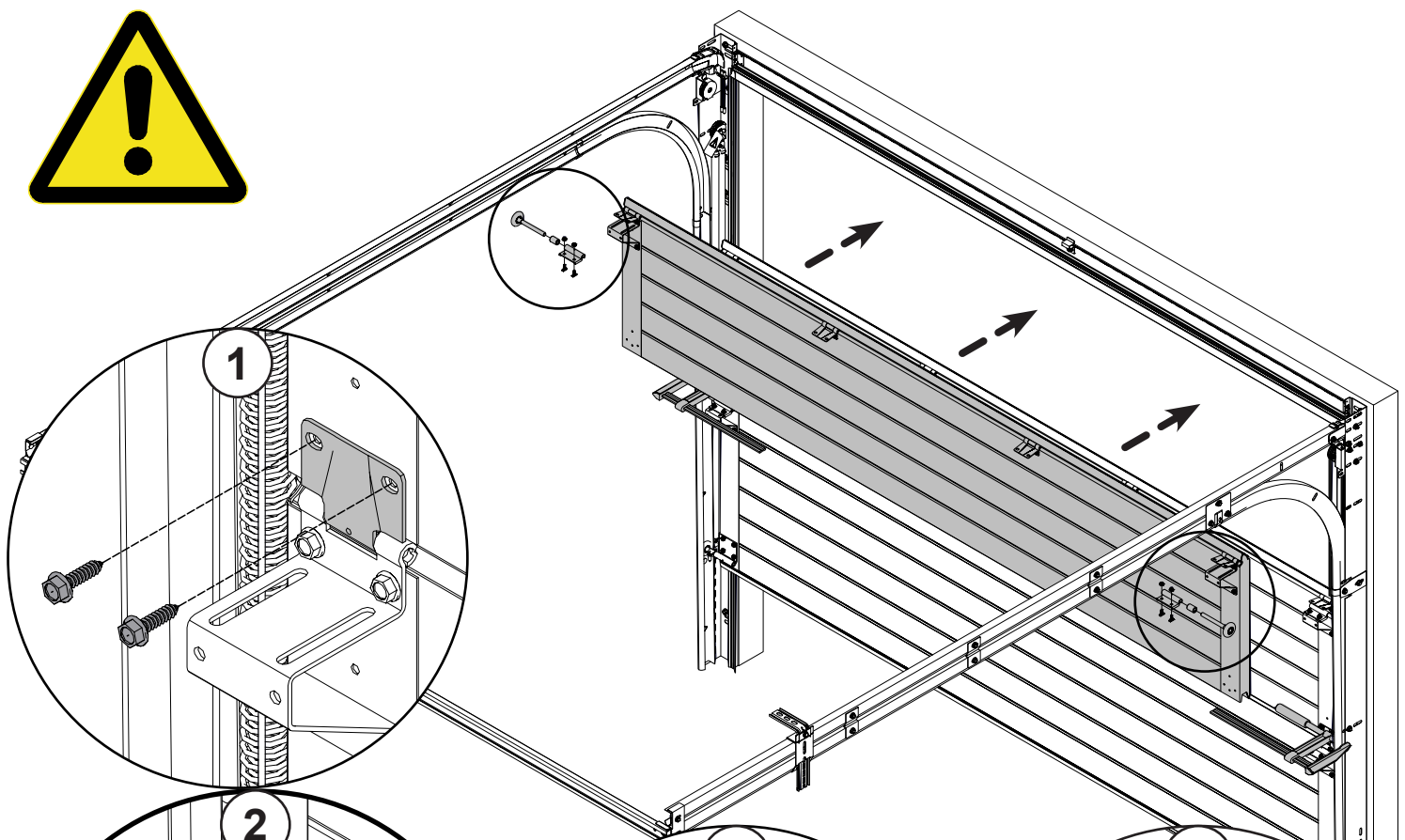

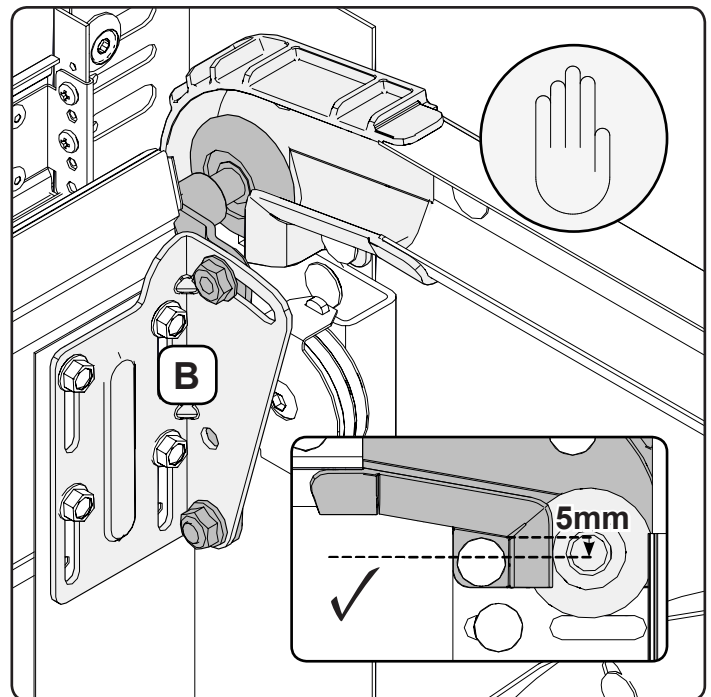
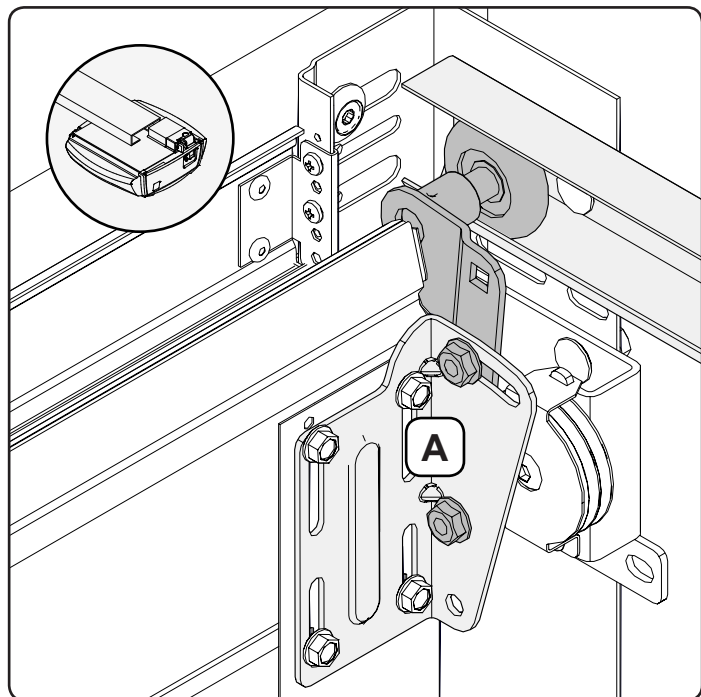
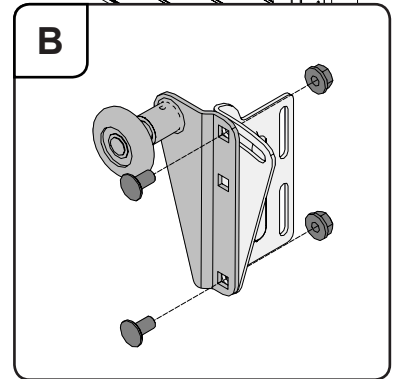
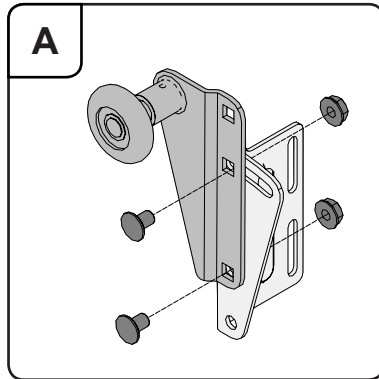
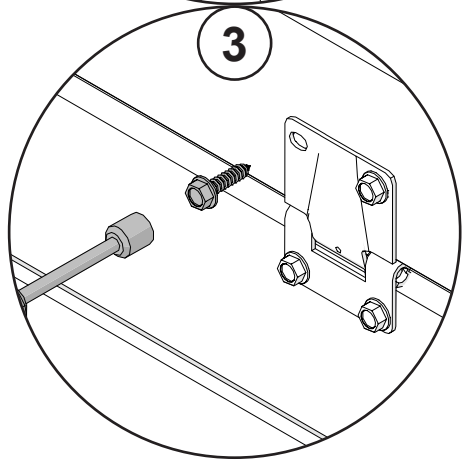
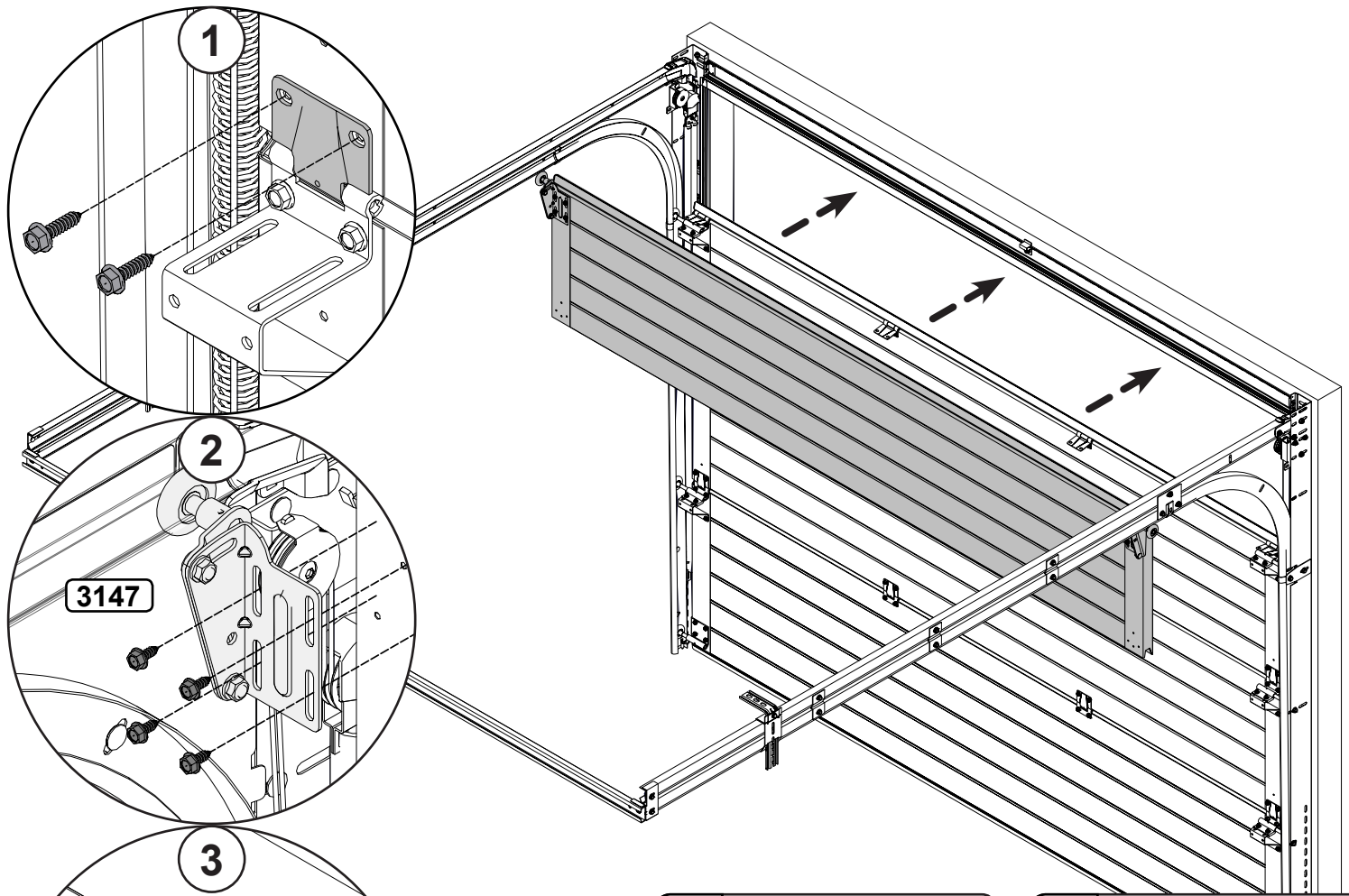



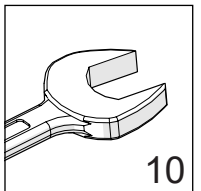
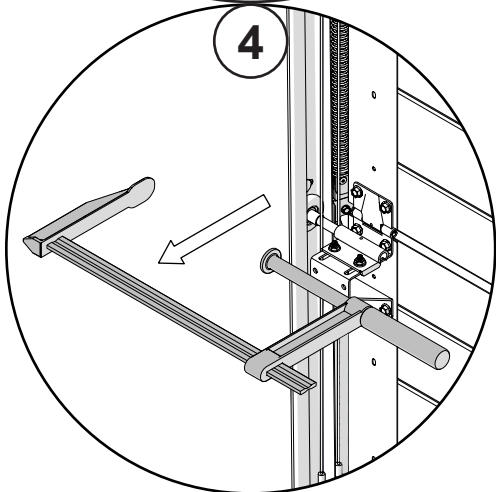
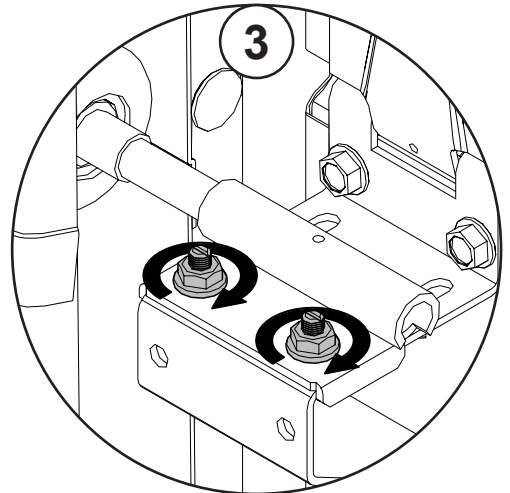
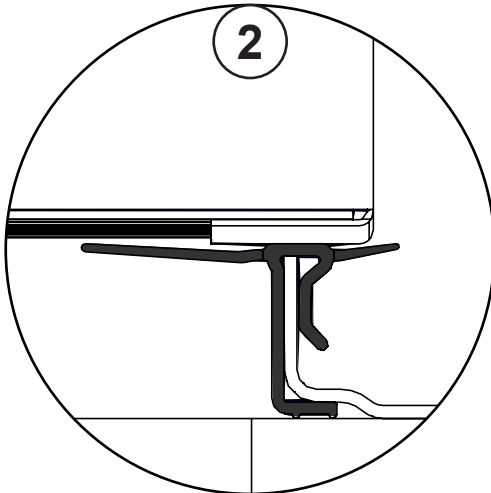
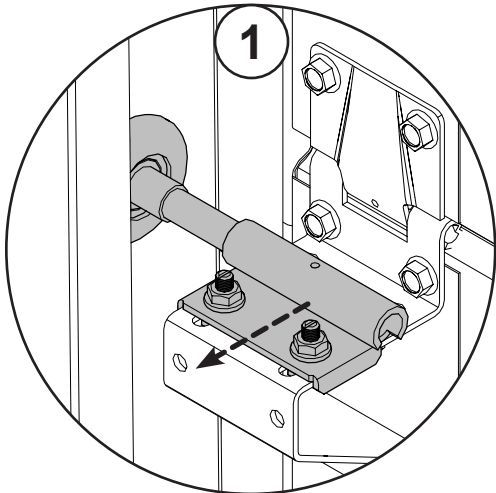
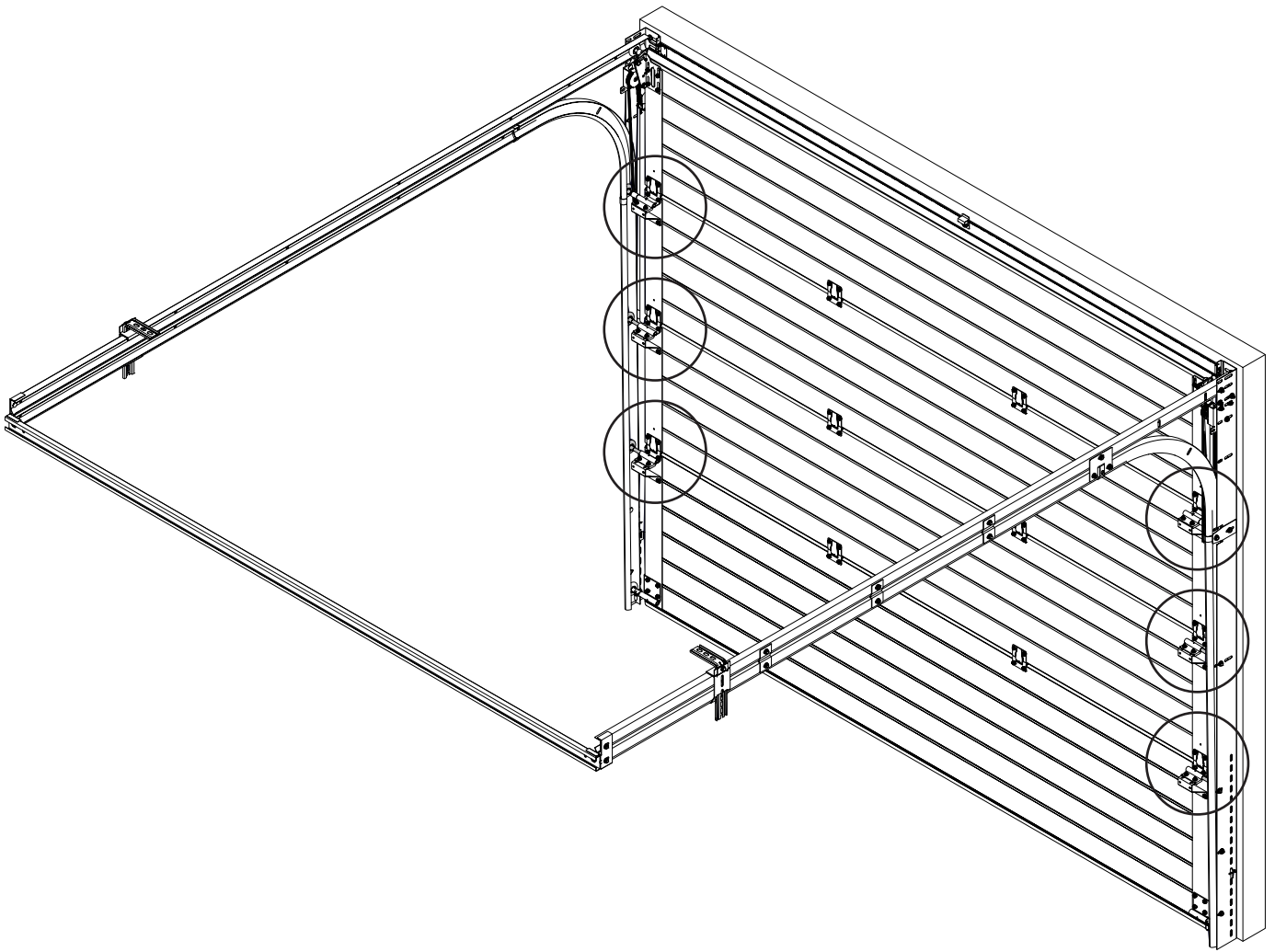

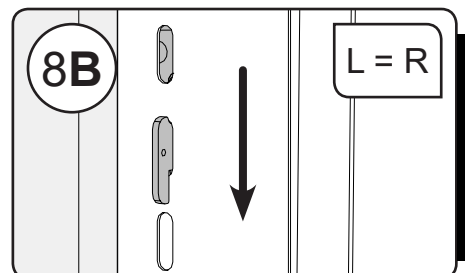
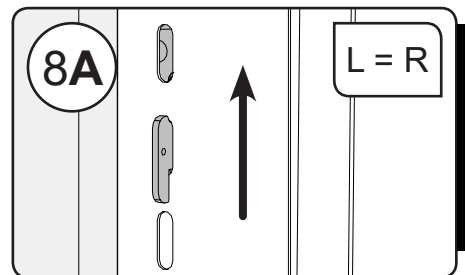
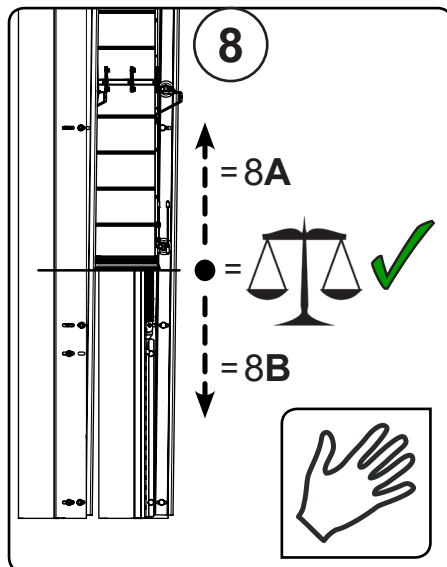
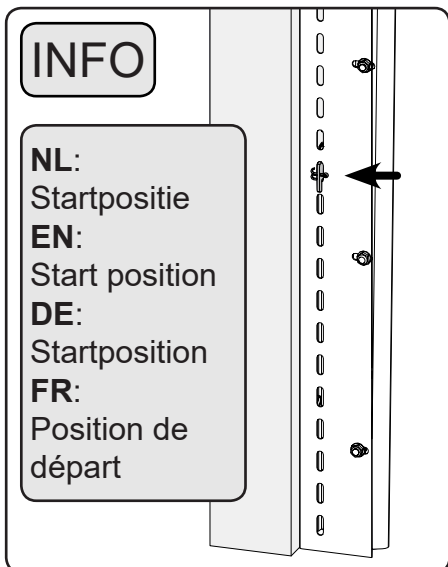
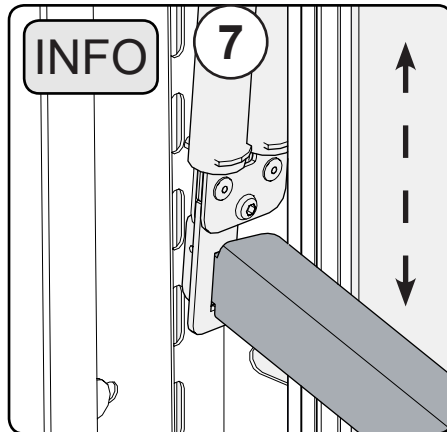
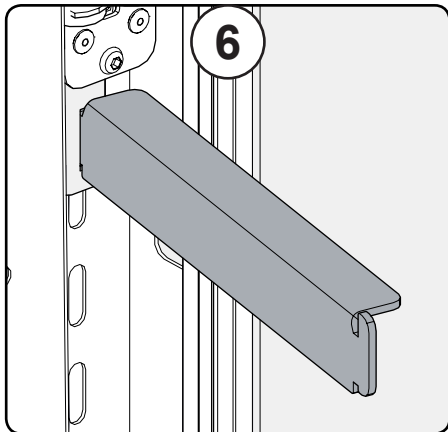
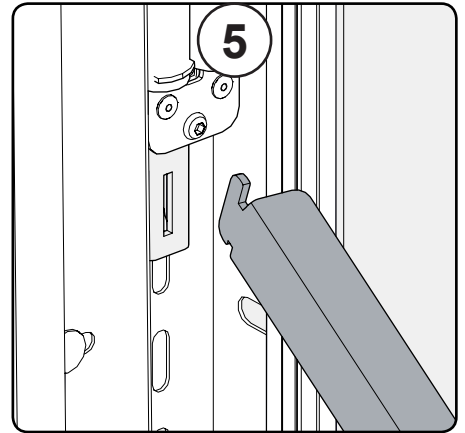
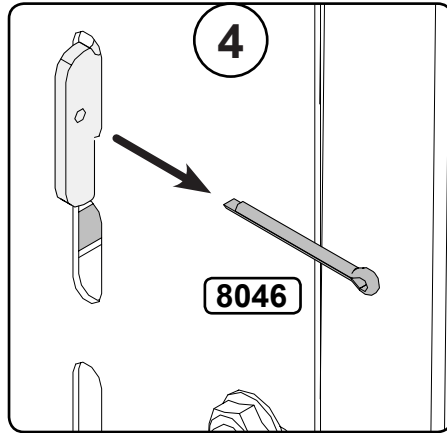
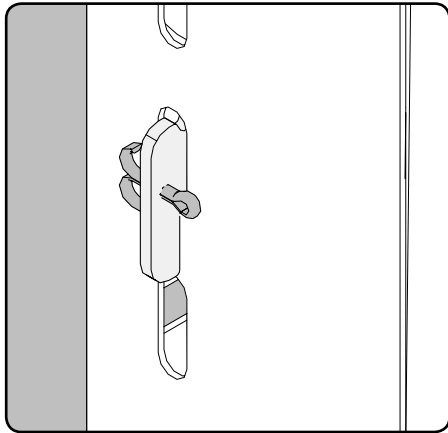
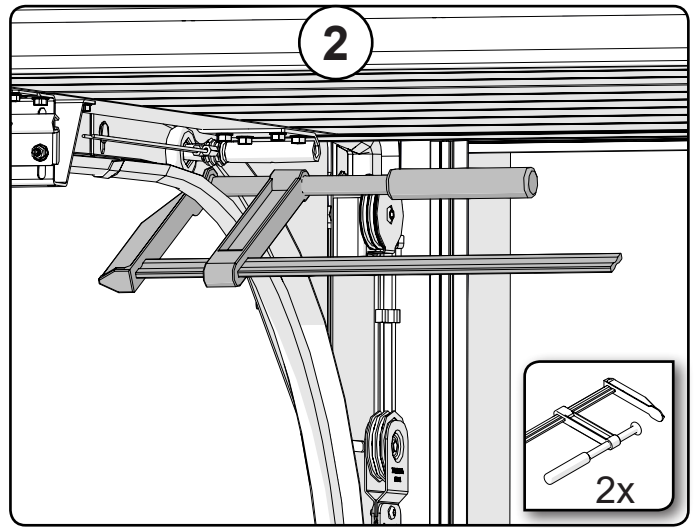
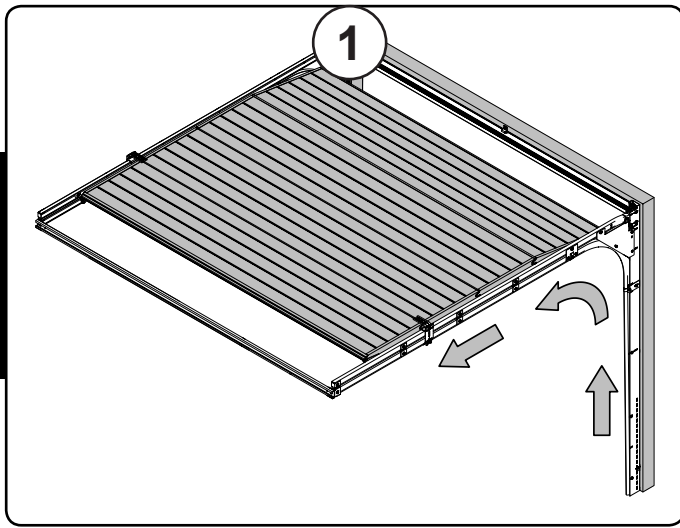

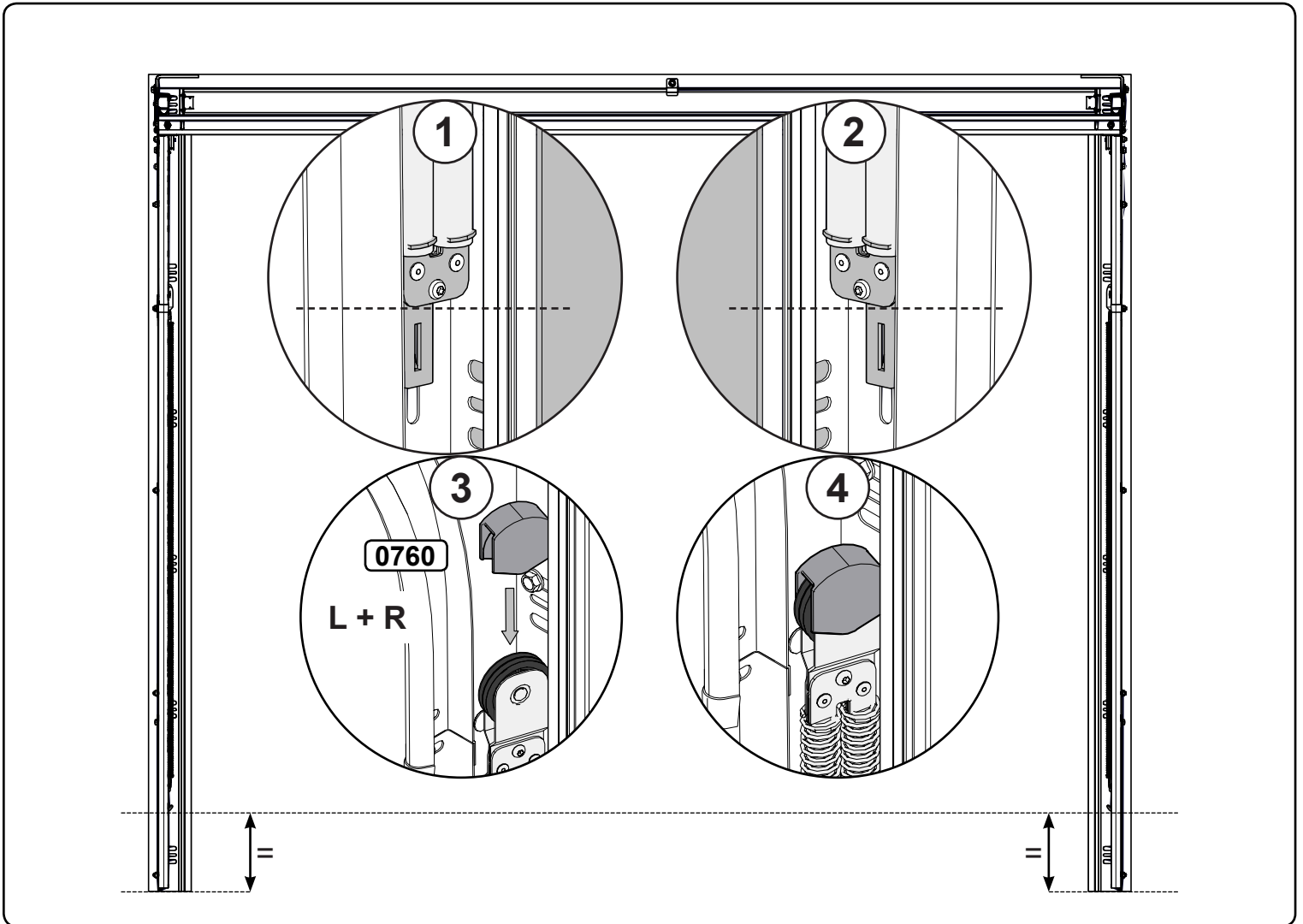
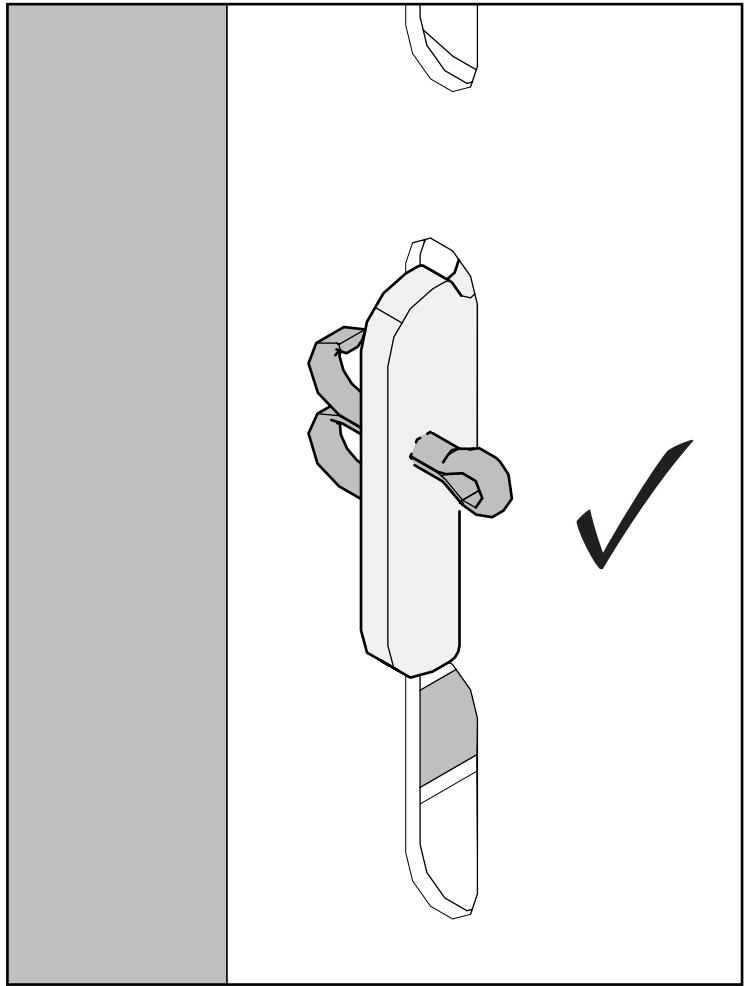
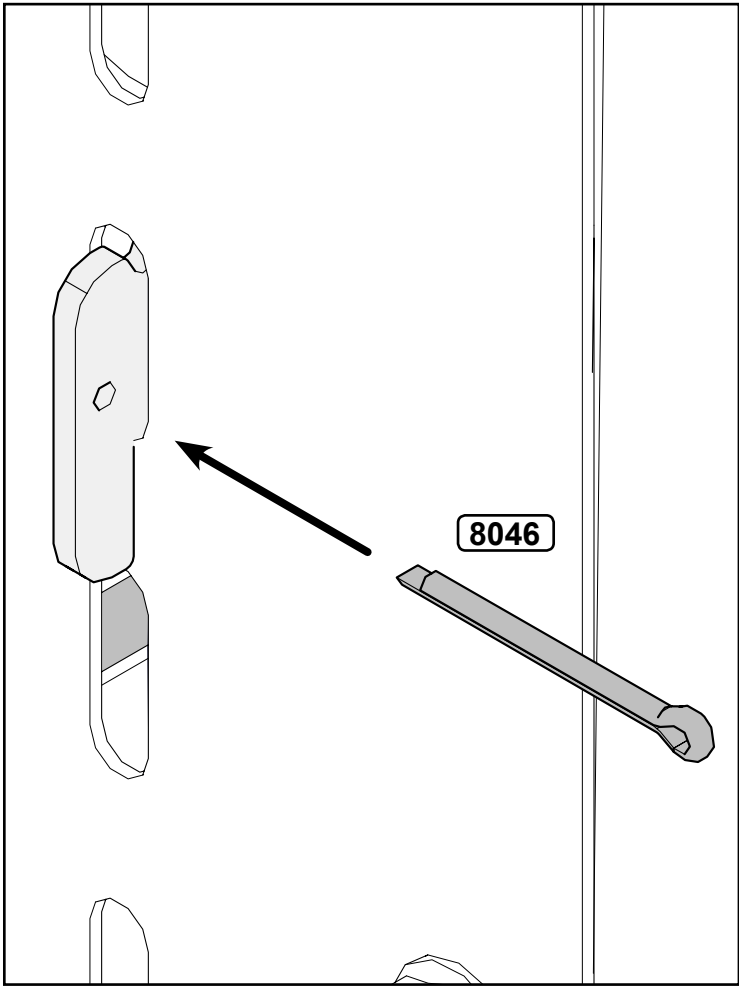

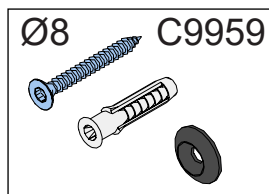
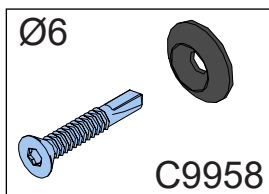
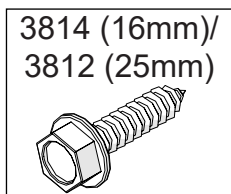
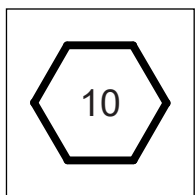
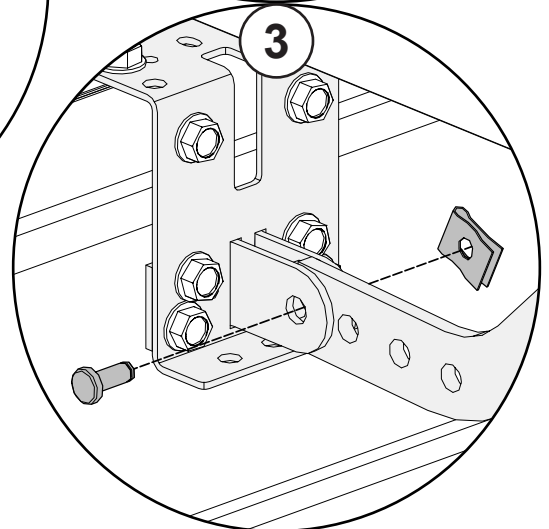
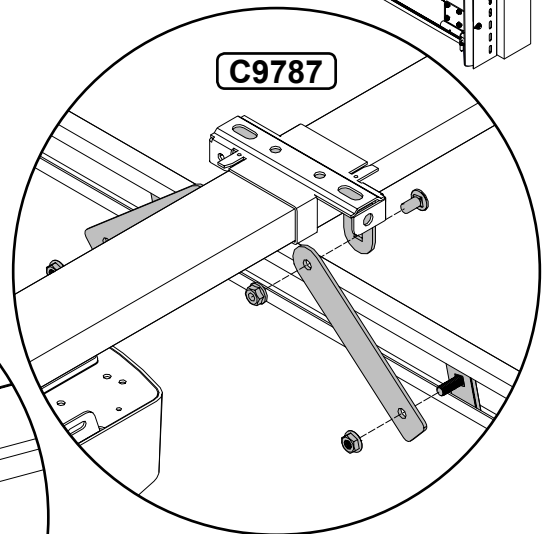
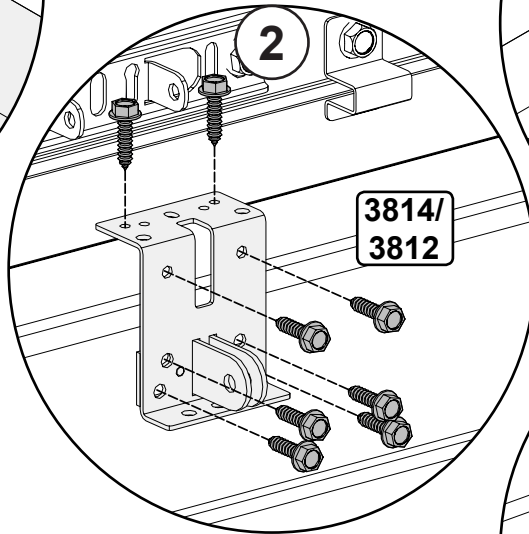
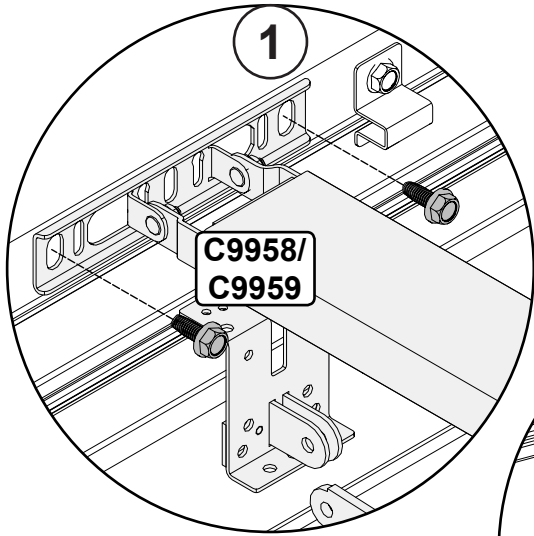
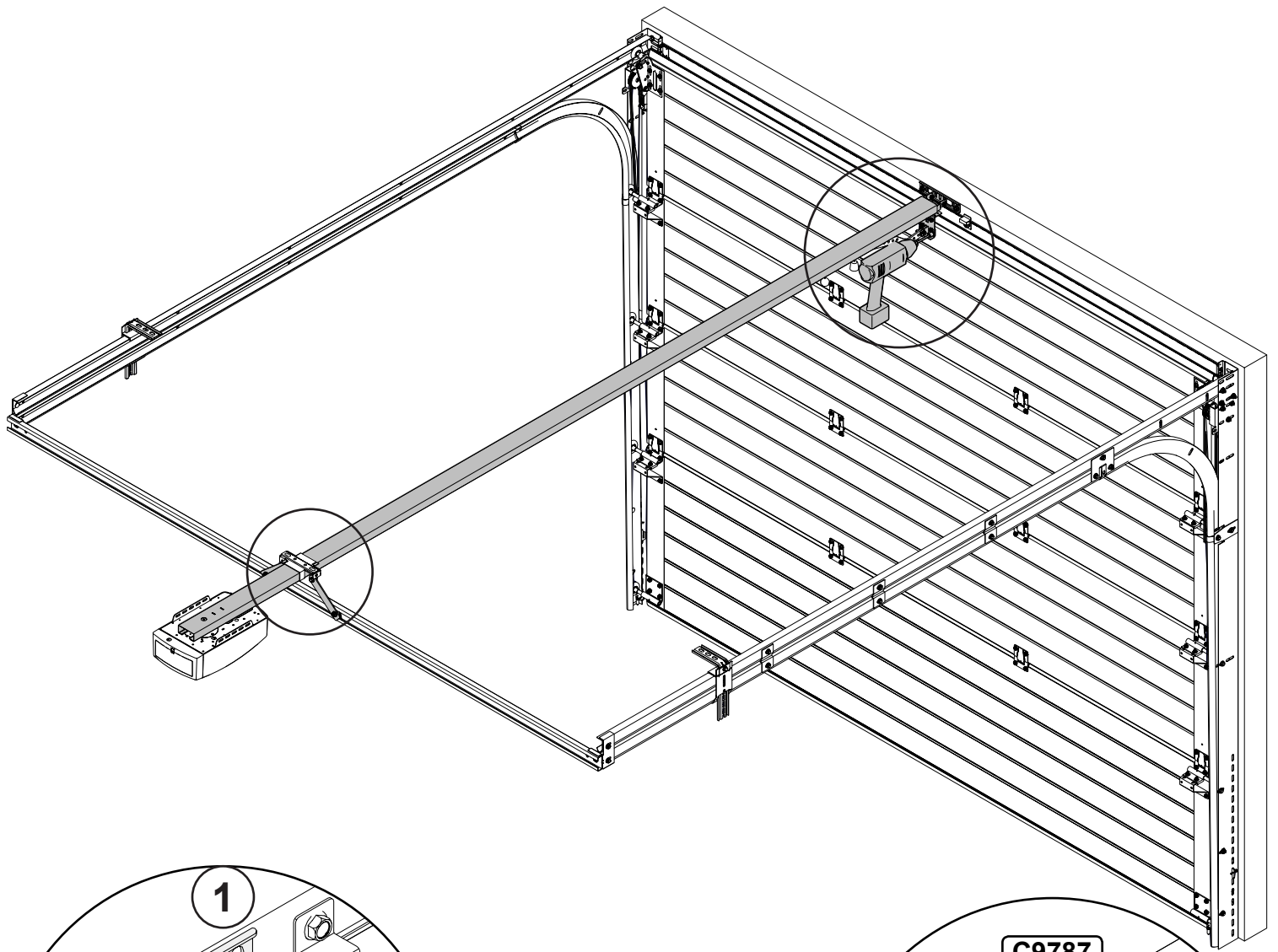



Scanporten AS | Eternitveien 44 | 3470 Slemmestad  
Telefon: 66 90 10 20 | [post@scanporten.no](mailto:post@scanporten.no) | [www.scanporten.no](http://www.scanporten.no)